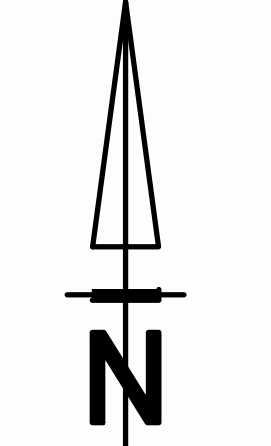

Appendix A

ROUTE ALIGNMENT OPTION DRAWINGS

- Key Plan
- Route 1: 4 x Drawings
- Route 2: 4 x Drawings
- Route 3: 4 x Drawings

LEGEND:

- ROUTE 01
- ROUTE 02
- ROUTE 03



KEY PLAN
NTS

	<p>CONSULTANTS:</p> <div style="display: flex; justify-content: space-between; align-items: center;"> <div style="text-align: center;"> </div> <div style="text-align: center;"> </div> <div style="text-align: center;"> </div> </div>	<p>CLIENT:</p> <div style="display: flex; justify-content: space-around; align-items: center;"> </div>	<p>APPROVED</p> <table style="width: 100%; border-collapse: collapse;"> <tr> <td style="width: 50%; border-bottom: 1px solid black; height: 20px;"></td> <td style="width: 50%; border-bottom: 1px solid black; height: 20px;"></td> </tr> <tr> <td style="font-size: 8px;">for CONSULTING ENG.</td> <td style="font-size: 8px;">for GAUTENG MANAGEMENT AGENCY</td> </tr> <tr> <td style="font-size: 8px;">DATE: _____</td> <td style="font-size: 8px;">DATE: _____</td> </tr> </table>			for CONSULTING ENG.	for GAUTENG MANAGEMENT AGENCY	DATE: _____	DATE: _____	<p>PROJECT:</p> <p style="text-align: center; font-weight: bold;">GAUTRAIN EXTENSION : PHASE 1</p>	<p>DRAWING DESCRIPTION:</p> <p style="text-align: center; font-weight: bold;">PROPOSED ROUTE ALIGNMENTS</p>	<p>SCALE</p> <p style="font-size: 8px;">NTS</p>	<p>TYPE OF PLANNING</p> <p style="font-size: 8px;">ROUTE DETERMINATION</p>
for CONSULTING ENG.	for GAUTENG MANAGEMENT AGENCY												
DATE: _____	DATE: _____												

No.	DATE	AMENDMENTS

ROUTE ALIGNMENT OPTION 1 DRAWINGS



South Africa



LEGEND:

- PROPOSED ROUTE ALIGNMENT 1
- PLATFORM / STATION
- VIADUCT
- TUNNEL

◀ TO FUTURE ROODEPOORT STATION

TO COSMO STATION ▶



LAYOUT PLAN
SCALE 1 : 10 000

DESIGN SPEED
180 km/h

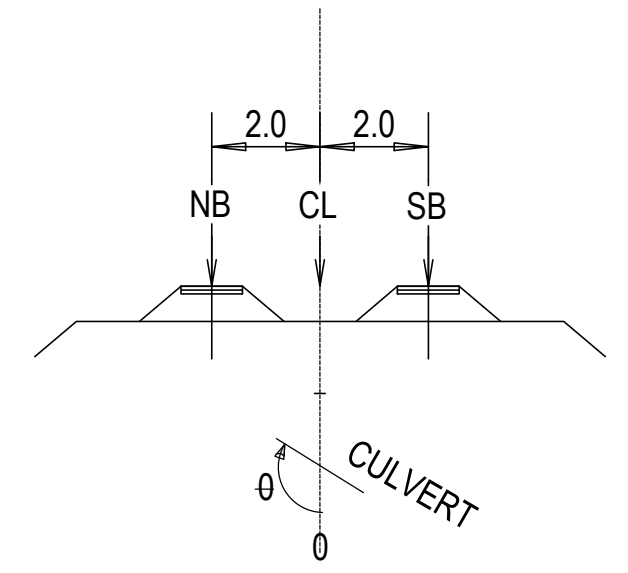

PROFILE OF GRADE LINE

HORIZONTAL SCALE 1 : 10000
VERTICAL SCALE 1 : 1000

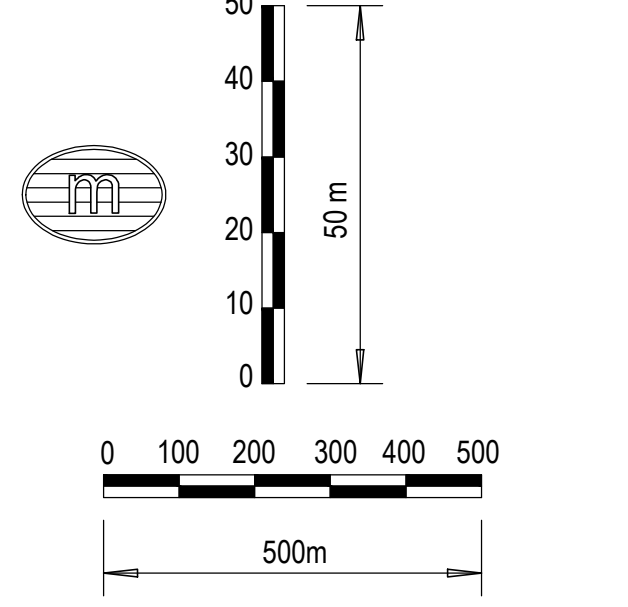

NGL
ROAD

SCALES:
Horizontal 1:10000
Vertical 1:1000
DATUM 1460.000

◀ TO FUTURE ROODEPOORT STATION

TO COSMO STATION ▶

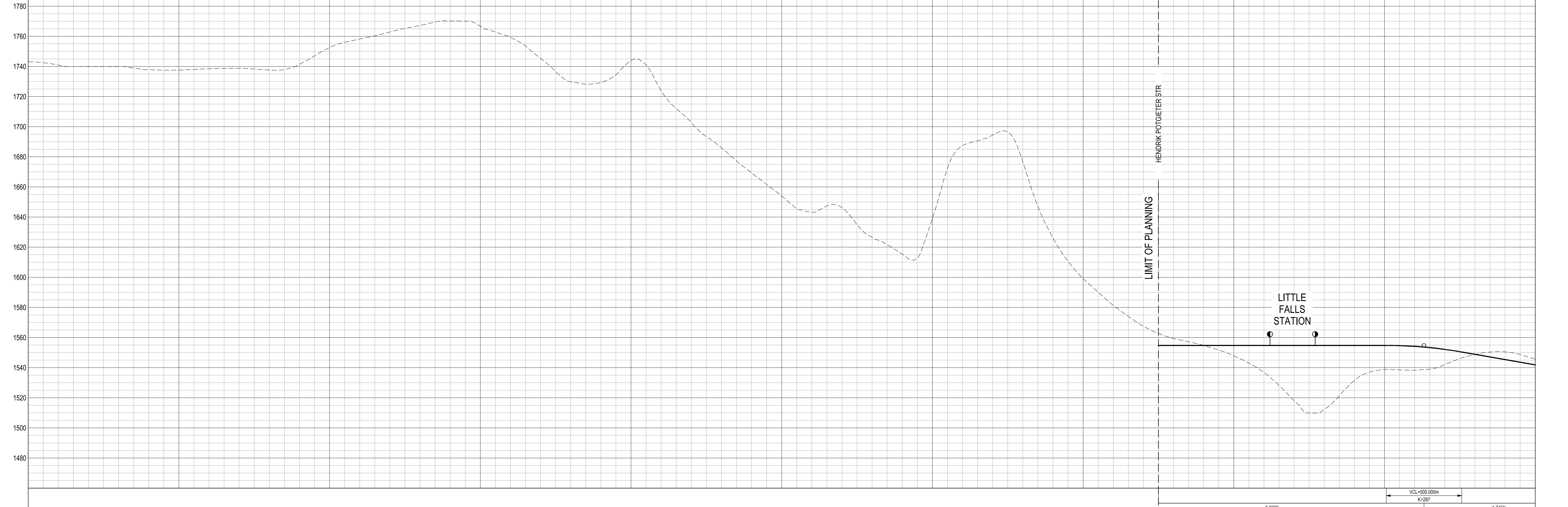

VERTICAL PROFILE GRADES
CENTRE LINE (CL)
GROUND LEVELS ON CL
HORIZONTAL ALIGNMENT
DISTANCE (m)
PLATFORMS
CROSS OVERS
TUNNELS
VIADUCTS

1480	1490	1500	1510	1520	1530	1540	1550	1560	1570	1580	1590	1600	1610	1620	1630	1640	1650	1660	1670	1680	1690	1700	1710	1720	1730	1740	1750	1760	1770	1780	1790	1800																																															
1480	1488	1496	1504	1512	1520	1528	1536	1544	1552	1560	1568	1576	1584	1592	1600	1608	1616	1624	1632	1640	1648	1656	1664	1672	1680	1688	1696	1704	1712	1720	1728	1736	1744	1752	1760	1768	1776	1784	1792	1800																																							
1480	1490	1500	1510	1520	1530	1540	1550	1560	1570	1580	1590	1600	1610	1620	1630	1640	1650	1660	1670	1680	1690	1700	1710	1720	1730	1740	1750	1760	1770	1780	1790	1800	1810	1820	1830	1840	1850	1860	1870	1880	1890	1900	1910	1920	1930	1940	1950	1960	1970	1980	1990	2000																											
CURVE 4 R=1600.0m L=240.000m A=619.66										DIRECTION 165°39'20"										CURVE 5 R=200.000m L=200.000m A=707.11										DIRECTION 171°03'47"										CURVE 6 R=1800.0m L=340.000m A=619.66										DIRECTION 218°18'50"										CURVE 7 R=3000.0m L=220.000m A=774.60										DIRECTION 210°32'10"									

No.	DATE	AMENDMENTS

CONSULTANTS:

AECOM **GIBB** **pwc** | South Africa **ZANECO**

LETSEMA **Alcost**

A BARNARD DESIGN
R VAN NEKERK DRAWN
F MARUTLA CHECKED

CLIENT:

GAUTENG REPUBLIC OF SOUTH AFRICA **GAUTRAIN** FOR THE PEOPLE ON THE MOVE **GAUTENG ON THE MOVE**

APPROVED

for CONSULTING ENG. DATE: _____

for GAUTENG MANAGEMENT AGENCY DATE: _____

PROJECT:

GAUTRAIN EXTENSION : PHASE 1

DRAWING DESCRIPTION:

PROPOSED ROUTE ALIGNMENT 1
(SHEET 1 OF 4)

SCALE: AS SHOWN

PAPER SIZE: A0

TYPE OF PLANNING: ROUTE DETERMINATION

DRAWING NUMBER: PRO-ROUTE 01-01

LEGEND:

- PROPOSED ROUTE ALIGNMENT 1
- PLATFORM / STATION
- VIADUCT
- TUNNEL

LAYOUT PLAN
SCALE 1 : 10 000

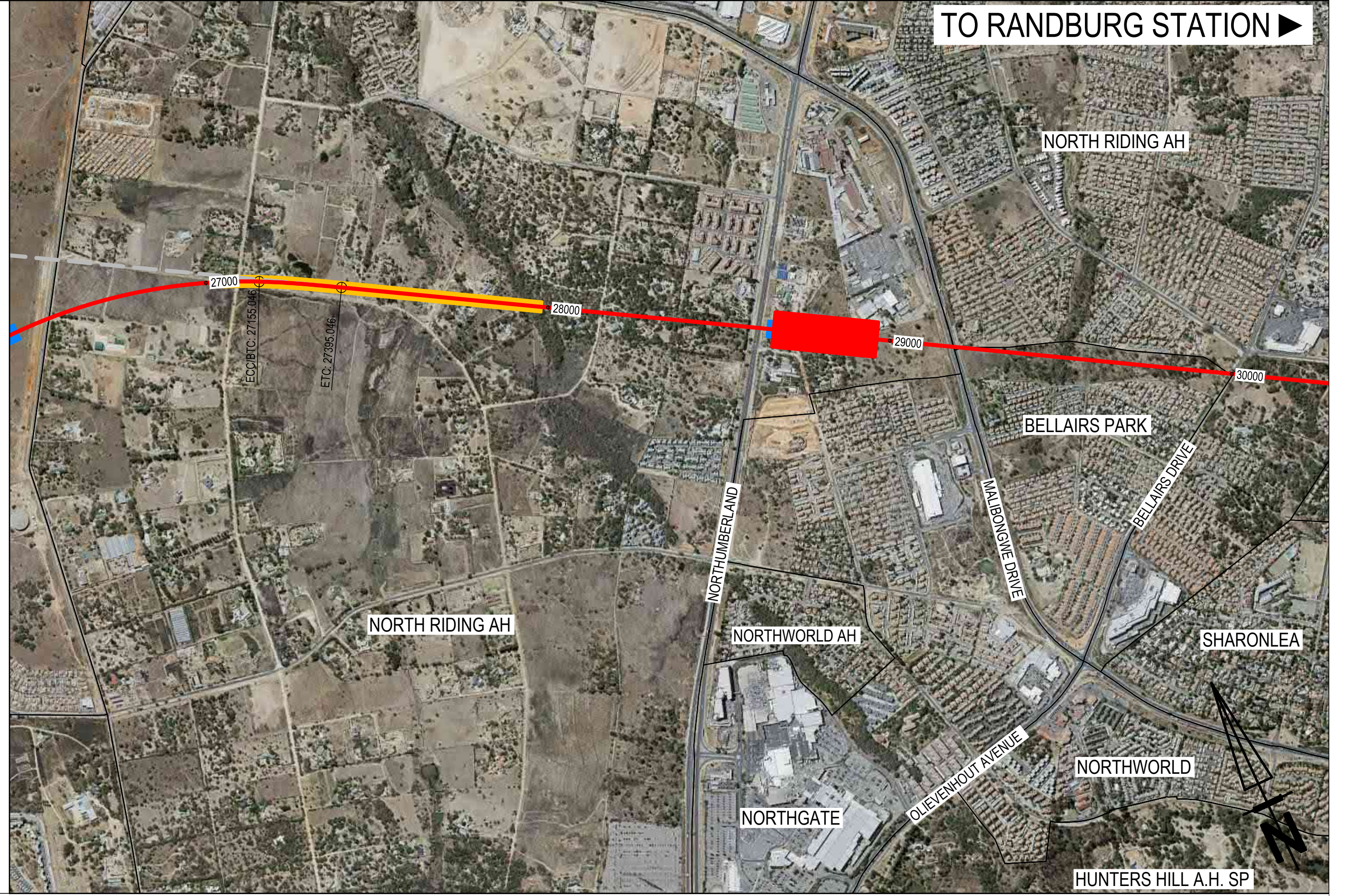

DESIGN SPEED
180 km/h

PROFILE OF GRADE LINE

HORIZONTAL SCALE 1 : 10000
VERTICAL SCALE 1 : 1000

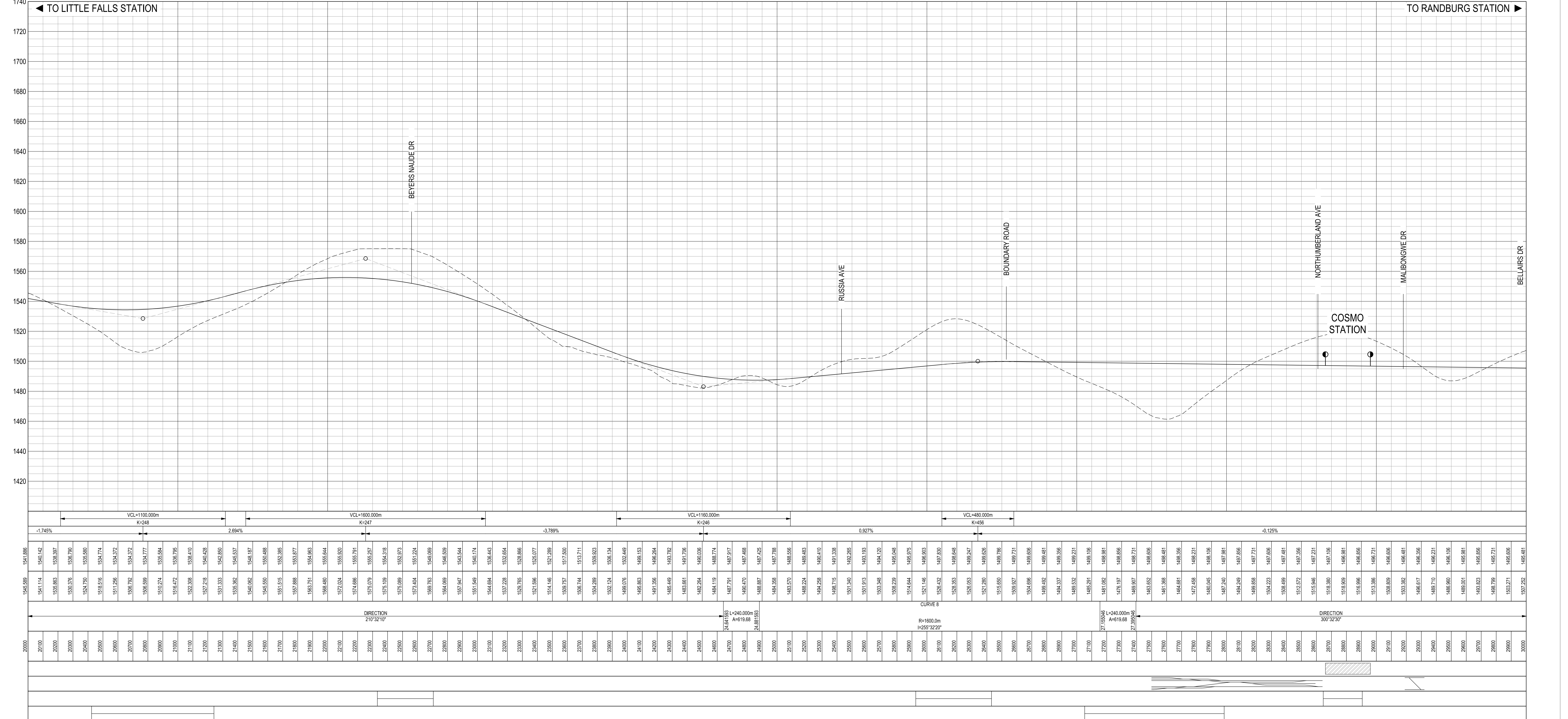

NGL
ROAD

SCALES:
Horizontal 1:10000
Vertical 1:1000
DATUM 1400.000

VERTICAL PROFILE GRADES	
CENTRE LINE (CL)	
GROUND LEVELS ON CL	
HORIZONTAL ALIGNMENT	
DISTANCE (m)	
PLATFORMS	
CROSS OVERS	
TUNNELS	
VIADUCTS	

No.	DATE	AMENDMENTS	CONSULTANTS:		CLIENT:		APPROVED	PROJECT:	DRAWING DESCRIPTION:		SCALE	TYPE OF PLANNING
							 for CONSULTING ENG. DATE:	 for GAUTENG MANAGEMENT AGENCY DATE:	GAUTRAIN EXTENSION : PHASE 1 PROPOSED ROUTE ALIGNMENT 1 (SHEET 2 OF 4)		AS SHOWN	ROUTE DETERMINATION
										PAPER SIZE	DRAWING NUMBER	
										A0	PRO-ROUTE 01-02	

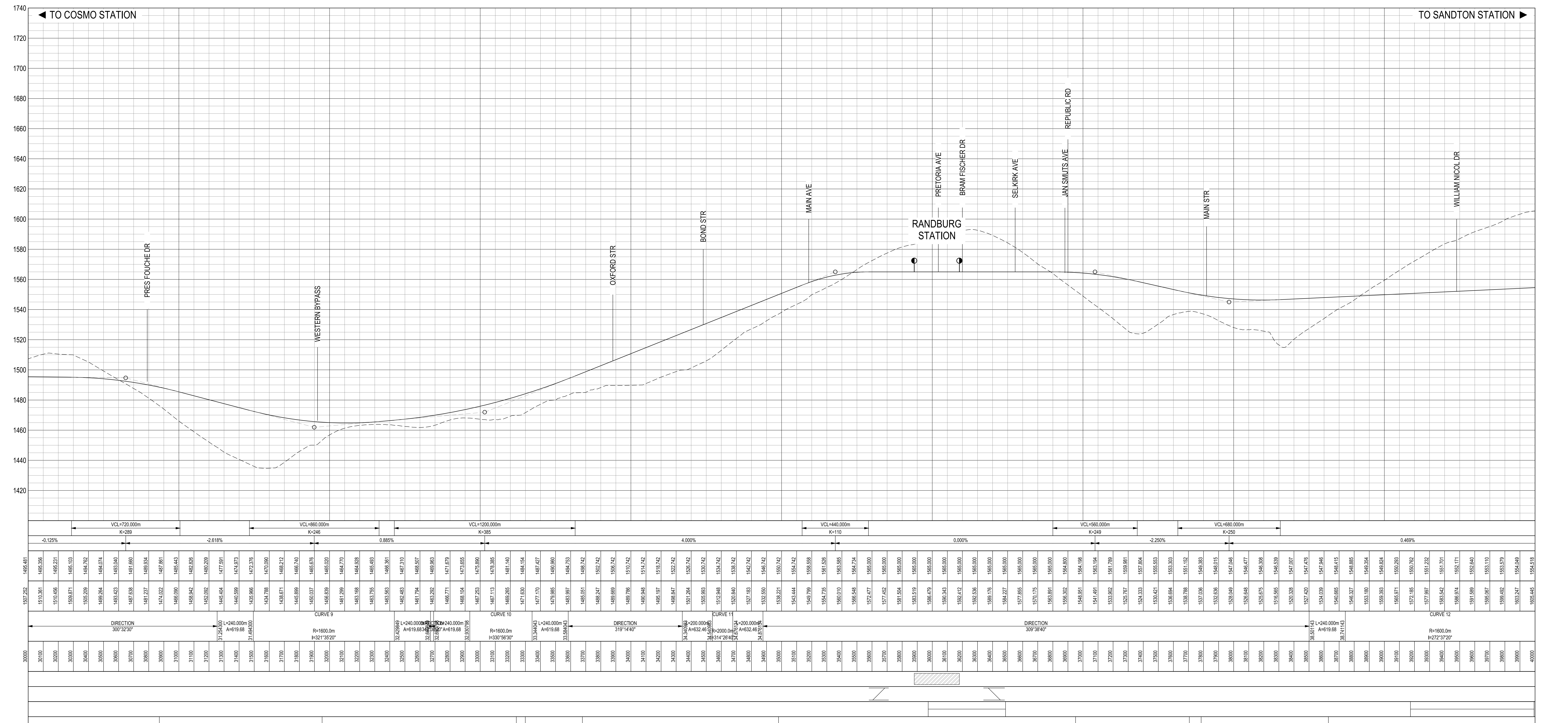
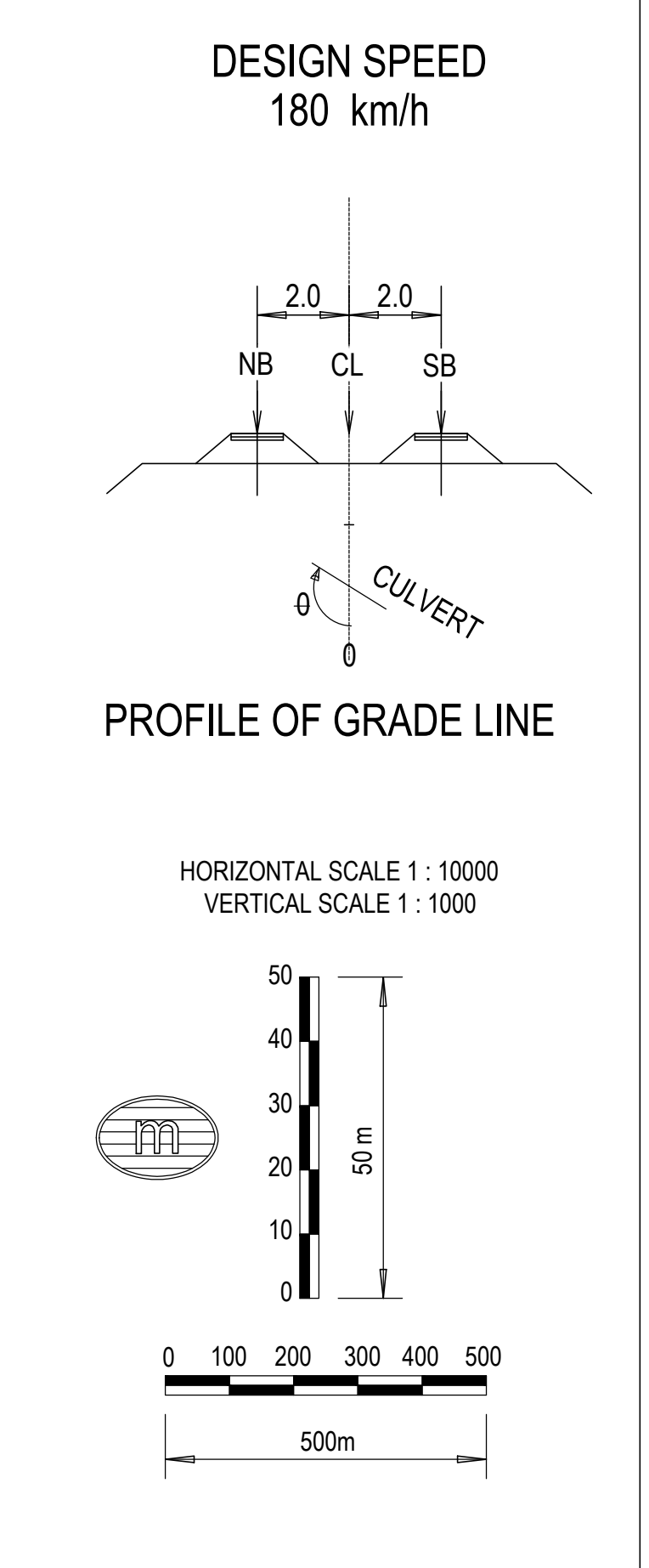

SCALES:
Horizontal 1:10000
Vertical 1:1000
DATUM 1400.000

VERTICAL PROFILE GRADES	
CENTRE LINE (CL)	
GROUND LEVELS ON CL	
HORIZONTAL ALIGNMENT	
DISTANCE (m)	
PLATFORMS	
CROSS OVERS	
TUNNELS	
VIADUCTS	

CONSULTANTS: 		CLIENT: 		APPROVED: for CONSULTING ENG. _____ for GAUTENG MANAGEMENT AGENCY _____ DATE: _____		PROJECT: GAUTRAIN EXTENSION : PHASE 1		DRAWING DESCRIPTION: PROPOSED ROUTE ALIGNMENT 1 (SHEET 3 OF 4)		SCALE: AS SHOWN PAPER SIZE: A0		TYPE OF PLANNING: ROUTE DETERMINATION DRAWING NUMBER: PRO-ROUTE 01-03	
-------------------------	--	--------------------	--	---	--	---	--	--	--	---	--	--	--

No.	DATE	AMENDMENTS

LEGEND:

- PROPOSED ROUTE ALIGNMENT 1
- PLATFORM / STATION
- VIADUCT
- TUNNEL

LAYOUT PLAN
SCALE 1 : 10 000

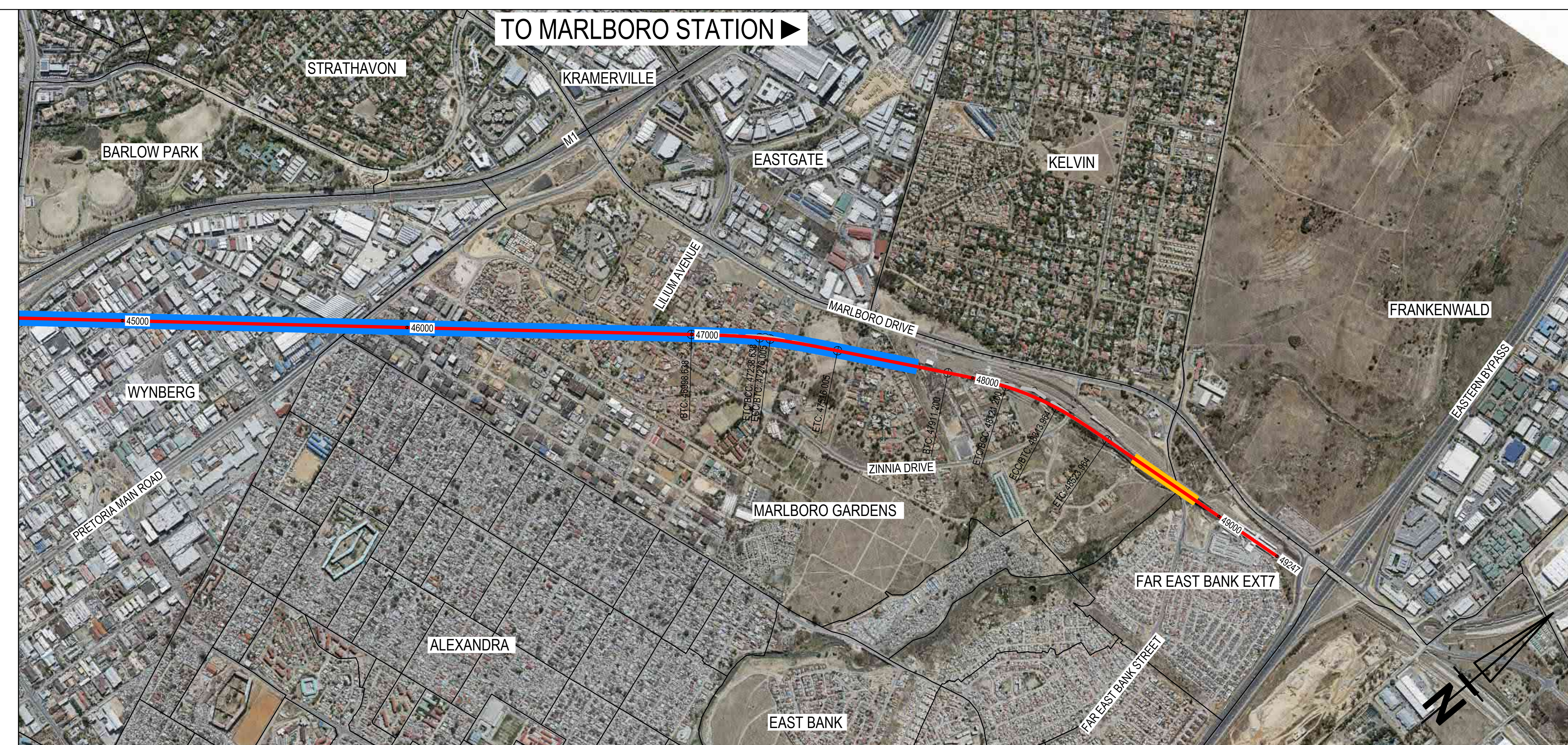
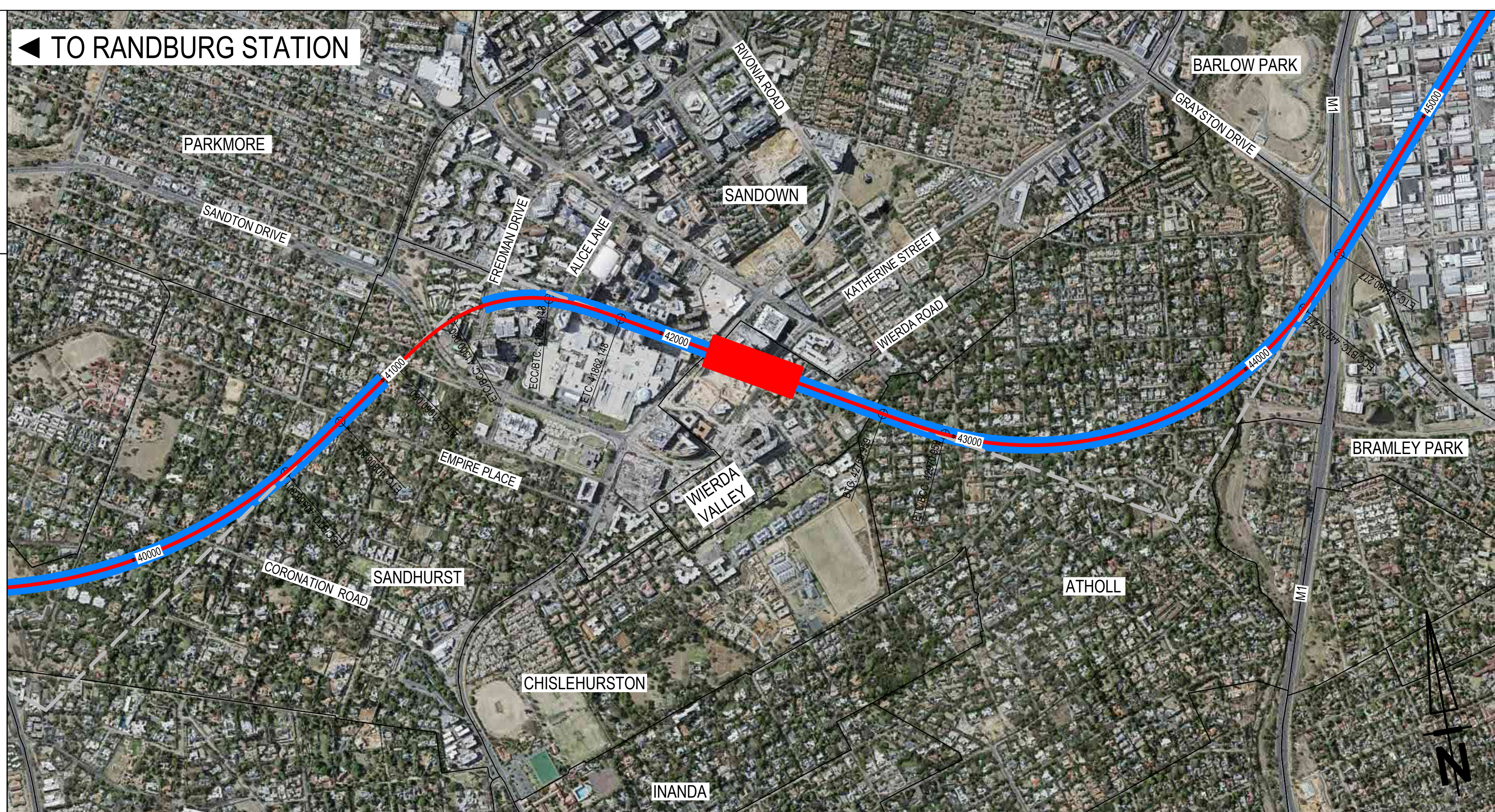

DESIGN SPEED
180 km/h

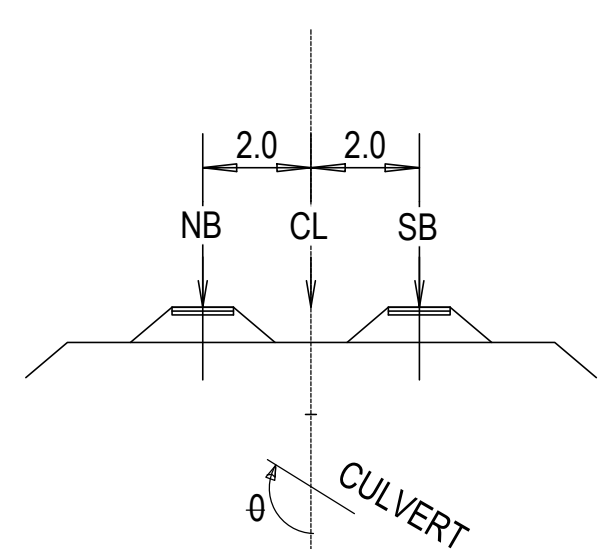

PROFILE OF GRADE LINE

HORIZONTAL SCALE 1 : 10000
VERTICAL SCALE 1 : 1000

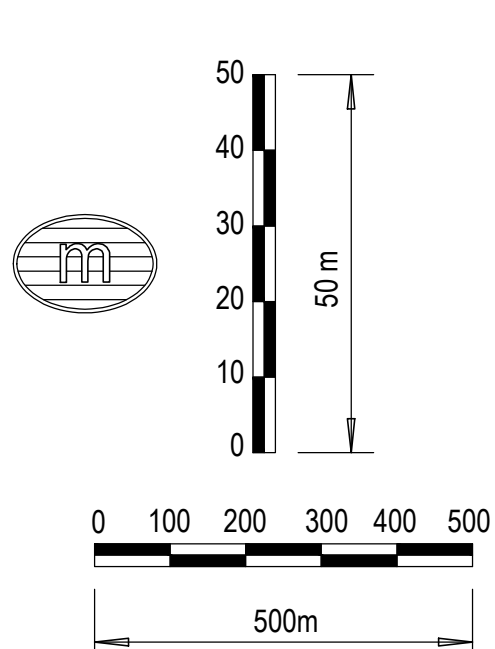

NGL
ROAD

SCALES:
Horizontal 1:10000
Vertical 1:1000
DATUM 1400.000

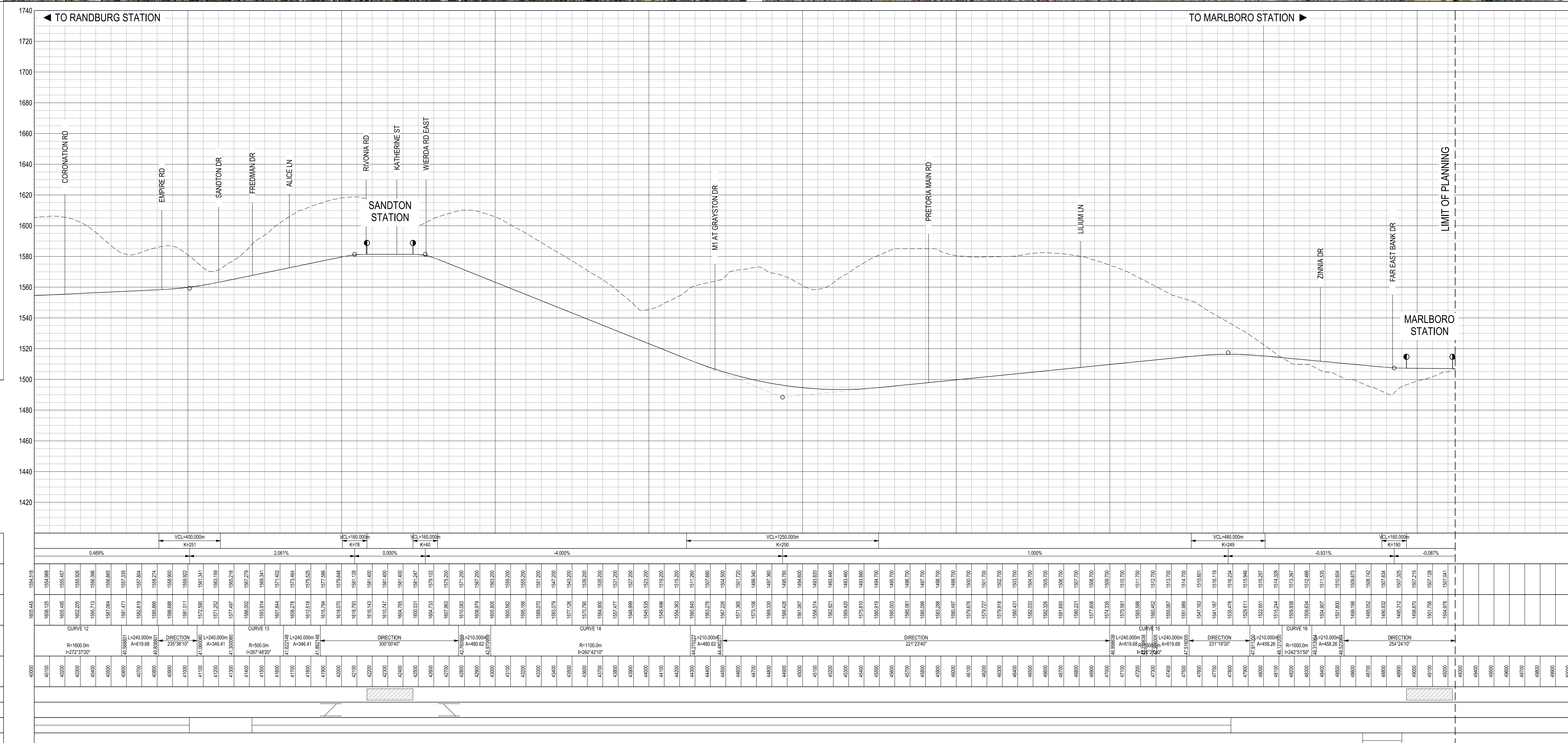

CONSULTANTS: AECOM GIBB <small>ENGINEERING & ARCHITECTURE</small>		CLIENT: GAUTENG <small>REPUBLIC OF SOUTH AFRICA</small>		APPROVED for CONSULTING ENG. _____ DATE: _____		PROJECT: GAUTRAIN EXTENSION : PHASE 1		DRAWING DESCRIPTION: PROPOSED ROUTE ALIGNMENT 1 (SHEET 4 OF 4)		SCALE AS SHOWN	TYPE OF PLANNING ROUTE DETERMINATION
				PAPER SIZE A0		DRAWING NUMBER PRO-ROUTE 01-04					

No.	DATE	AMENDMENTS

ROUTE ALIGNMENT OPTION 2 DRAWINGS



South Africa





LAYOUT PLAN
SCALE 1 : 10 000

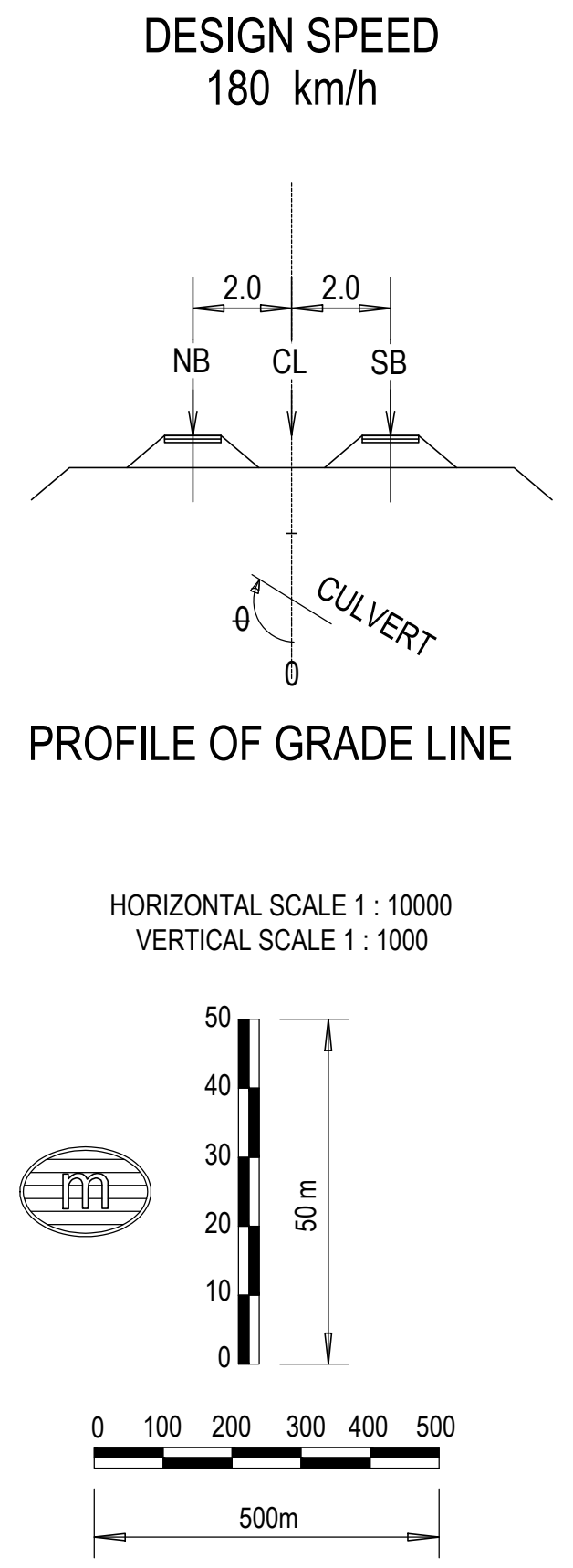

DESIGN SPEED
180 km/h

NGL

ROAD

SCALES:
Horizontal 1:10000
Vertical 1:1000
DATUM 1500.000

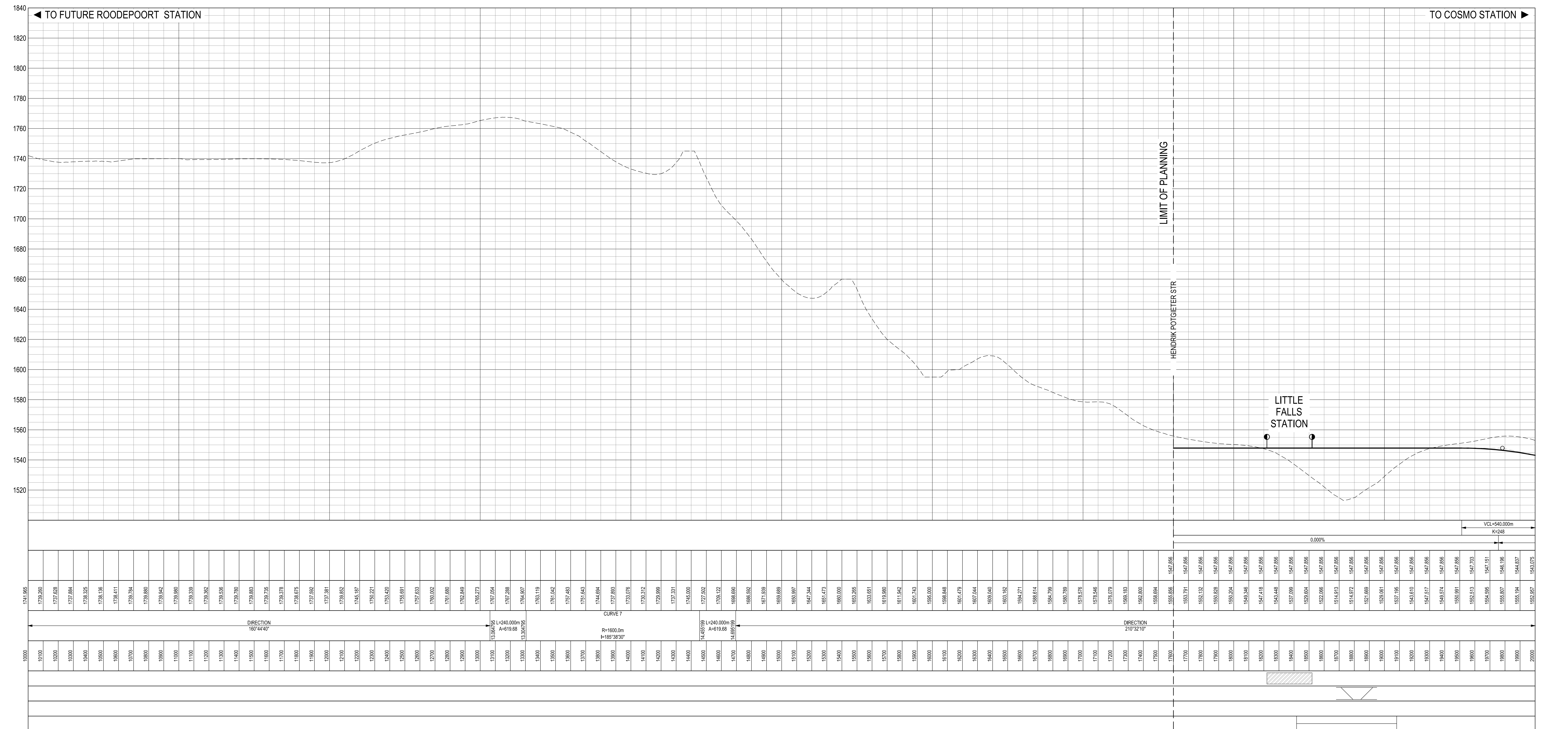

VERTICAL PROFILE GRADES	
CENTRE LINE (CL)	
GROUND LEVELS ON CL	
HORIZONTAL ALIGNMENT	
DISTANCE (m)	
PLATFORMS	
CROSS OVERS	
TUNNELS	
VIADUCTS	

	CONSULTANTS: 	A BARNARD DESIGN R VAN NIEKERK DRAWN F MARUTLA CHECKED	CLIENT: 	APPROVED for CONSULTING ENG. for GAUTENG MANAGEMENT AGENCY DATE: _____	PROJECT: GAUTRAIN EXTENSION : PHASE 1	DRAWING DESCRIPTION: PROPOSED ROUTE ALIGNMENT 2 (SHEET 1 OF 4)	SCALE AS SHOWN PAPER SIZE A0	TYPE OF PLANNING ROUTE DETERMINATION DRAWING NUMBER PRO-ROUTE 02-01
No.	DATE	AMENDMENTS						

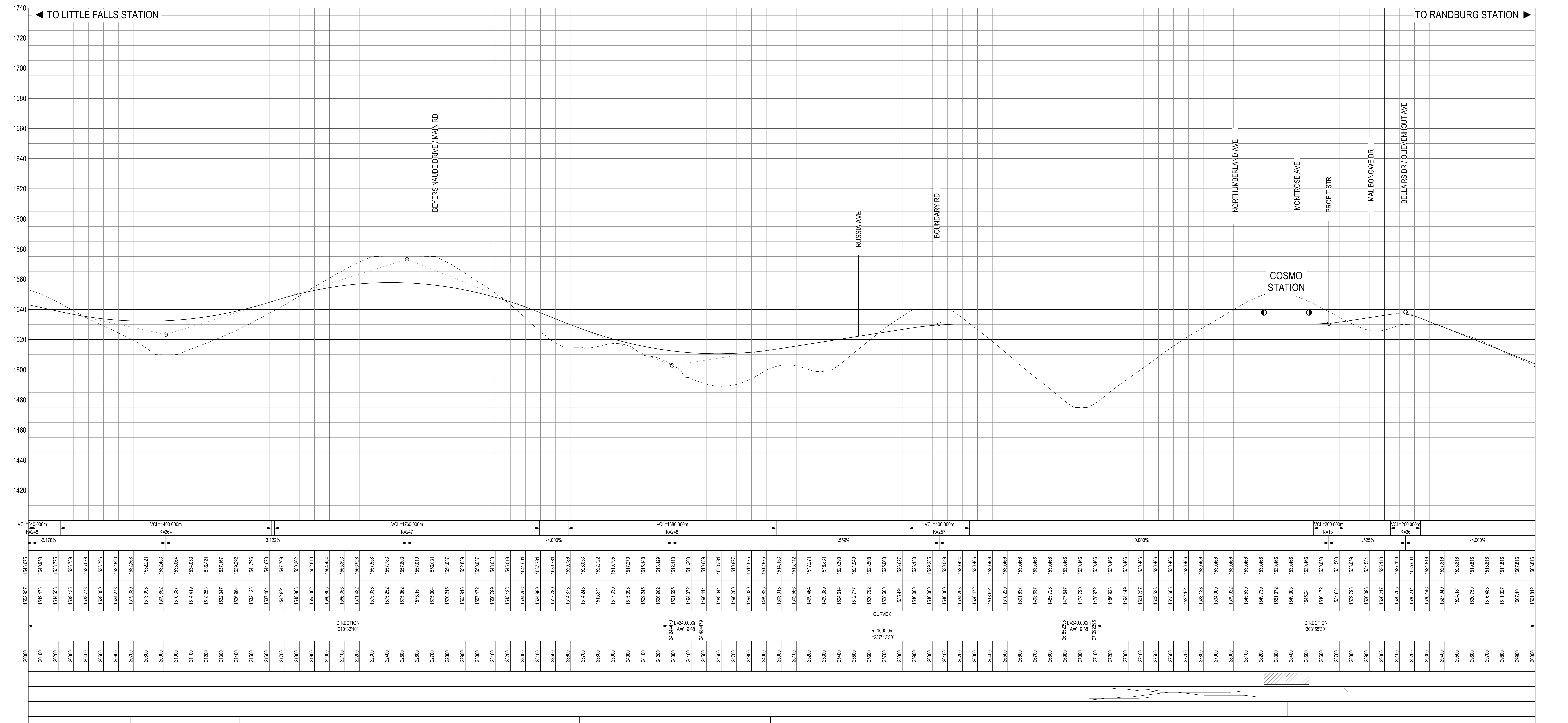
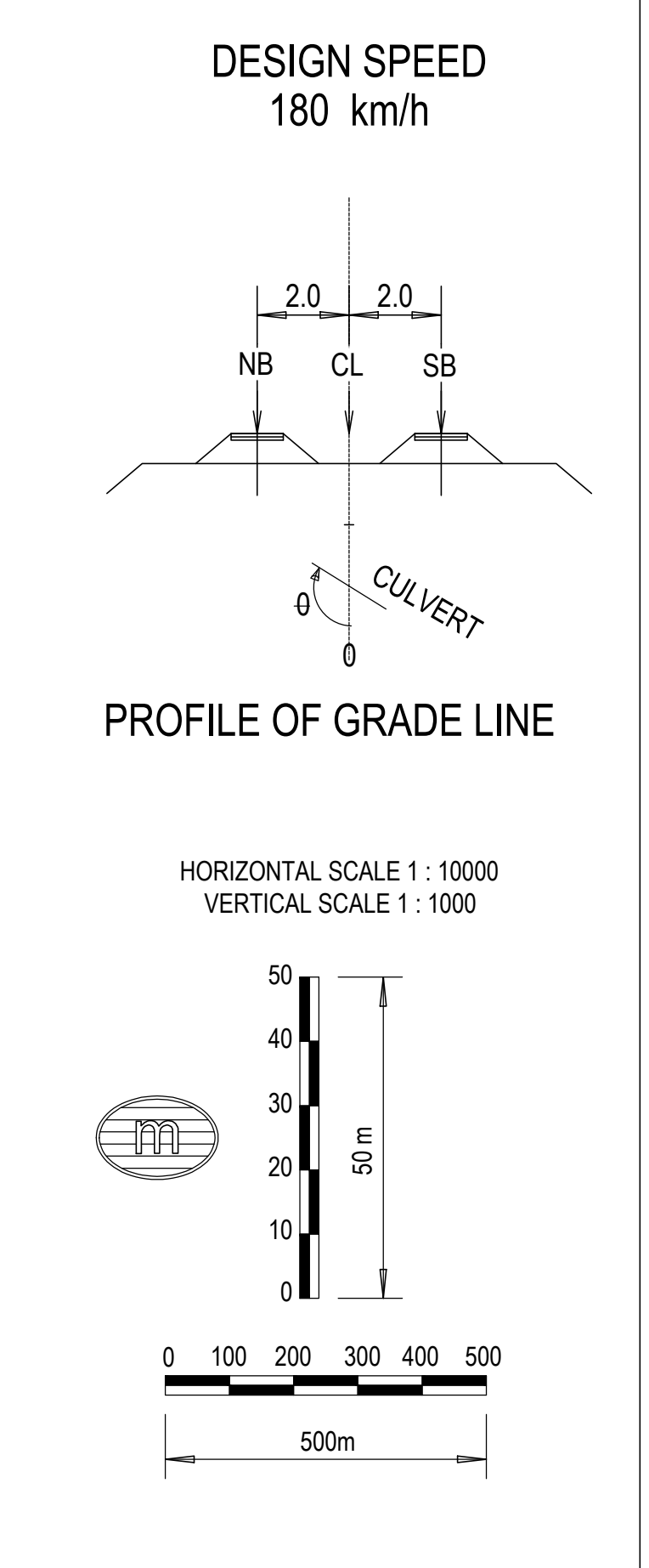

NGL -----
ROAD _____

SCALES:
Horizontal 1:10000
Vertical 1:1000
DATUM 1400.000

VERTICAL PROFILE GRADES
CENTRE LINE (CL)
GROUND LEVELS ON CL
HORIZONTAL ALIGNMENT
DISTANCE (m)
PLATFORMS
CROSS OVERS
TUNNELS
VIADUCTS

No.	DATE	AMENDMENTS	CLIENTS/CONSULTANTS:	CLIENT:	APPROVED	PROJECT:	DRAWING DESCRIPTION:	SCALE	TYPE OF PLANNING
					 for CONSULTING ENG. DATE:	 for GAUTENG MANAGEMENT AGENCY DATE:	GAUTRAIN EXTENSION : PHASE 1	PROPOSED ROUTE ALIGNMENT 2 (SHEET 2 OF 4)	AS SHOWN PAPER SIZE A0

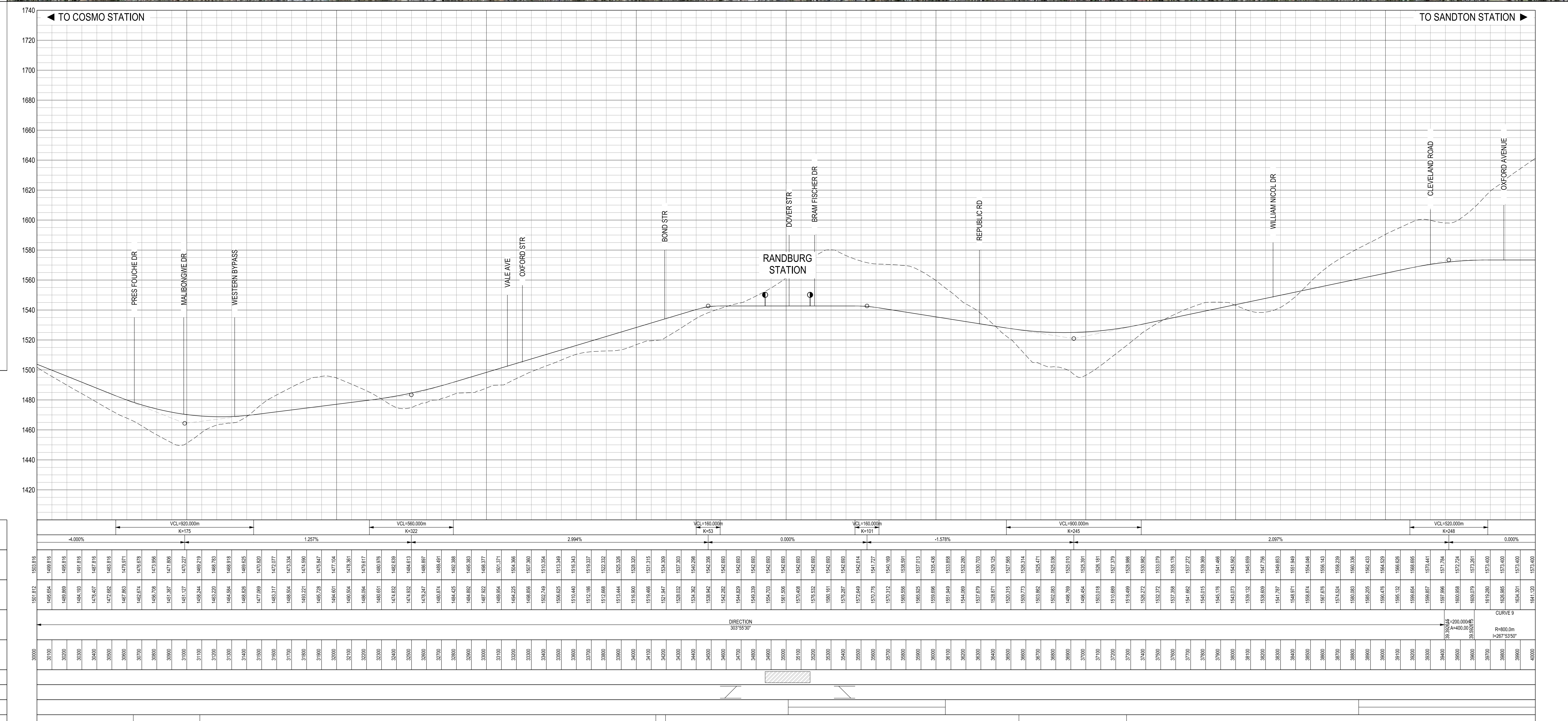
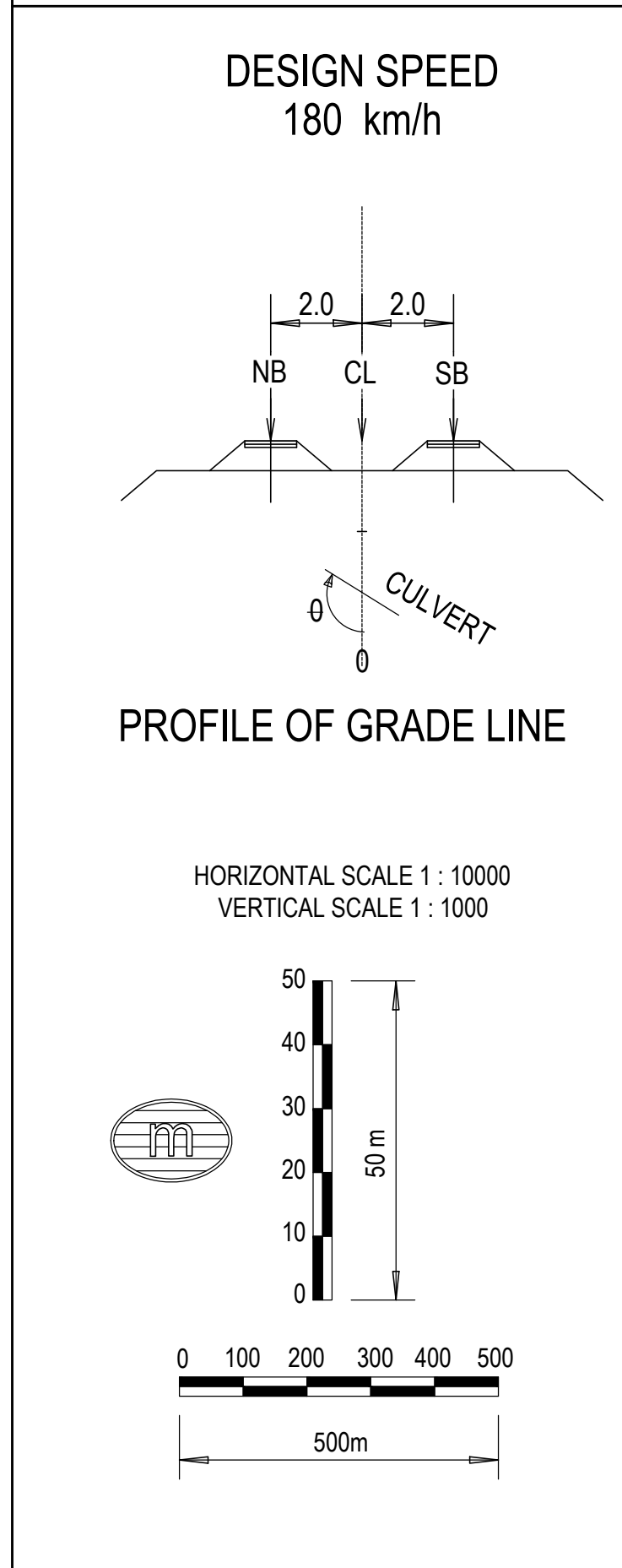
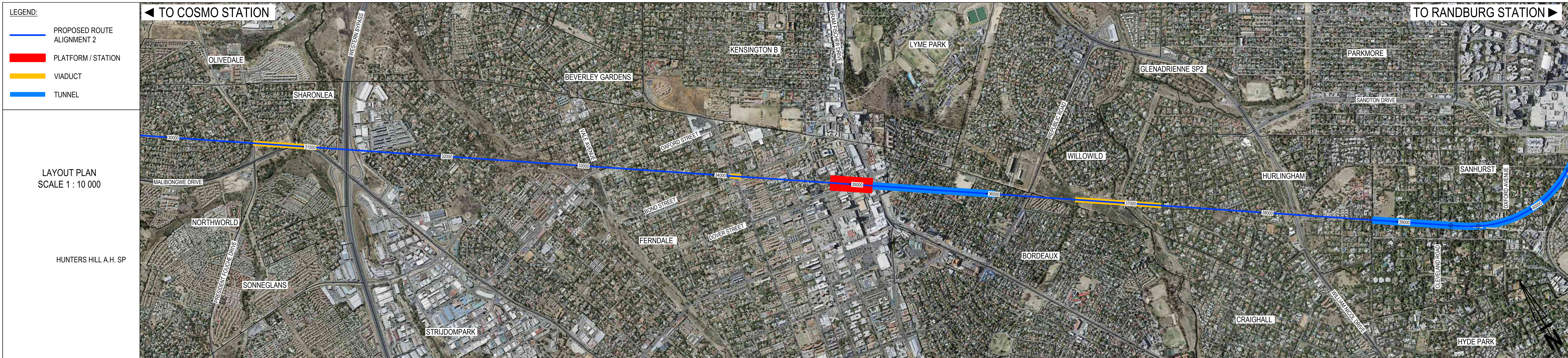

NGL	-----
ROAD	-----
SCALES: Horizontal 1:10000 Vertical 1:1000 DATUM 1400.000	
VERTICAL PROFILE GRADES	
CENTRE LINE (CL)	
GROUND LEVELS ON CL	
HORIZONTAL ALIGNMENT	
DISTANCE (m)	
PLATFORMS	
CROSS OVERS	
TUNNELS	
VIADUCTS	

CONSULTANTS: AECOM GIBB <small>ENGINEERING & ARCHITECTURE</small>		CLIENT: GAUTENG <small>REPUBLIC OF SOUTH AFRICA</small>		APPROVED for CONSULTING ENG. _____ DATE: _____		PROJECT: GAUTRAIN EXTENSION : PHASE 1		DRAWING DESCRIPTION: PROPOSED ROUTE ALIGNMENT 2 (SHEET 3 OF 4)		SCALE AS SHOWN PAPER SIZE A0		TYPE OF PLANNING ROUTE DETERMINATION DRAWING NUMBER ALT ROUTE 02-03	
No.	DATE	AMENDMENTS		A BARNARD DESIGN R VAN NIEKERK DRAWN F MARUTLA CHECKED		for GAUTENG MANAGEMENT AGENCY DATE: _____		R=800.0m A=400.00 I=267°53'50"					

LEGEND:

- PROPOSED ROUTE ALIGNMENT 2
- PLATFORM / STATION
- VIADUCT
- TUNNEL

LAYOUT PLAN
SCALE 1 : 10 000

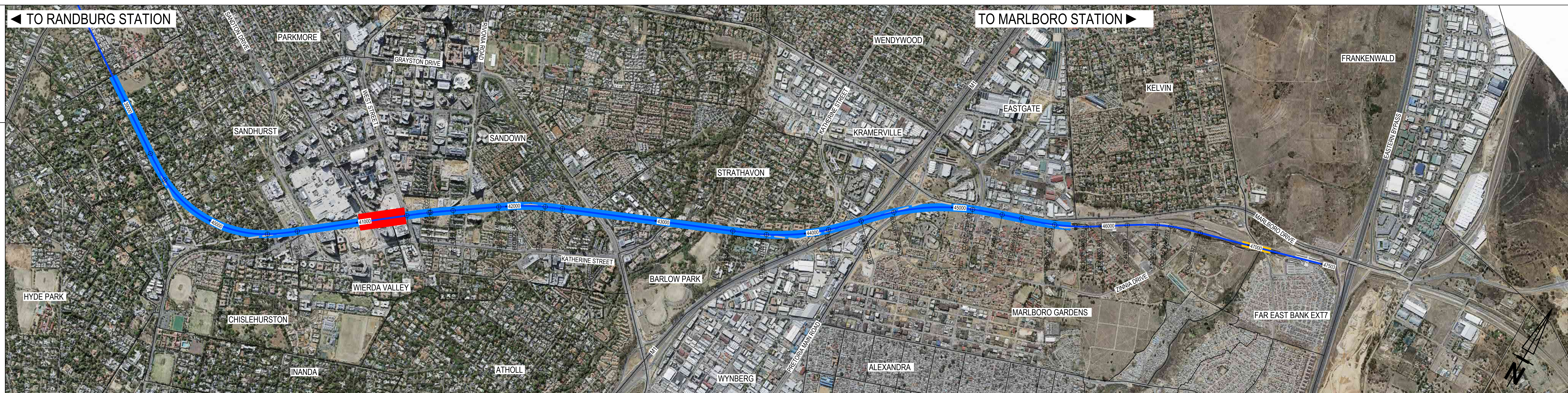

DESIGN SPEED
180 km/h

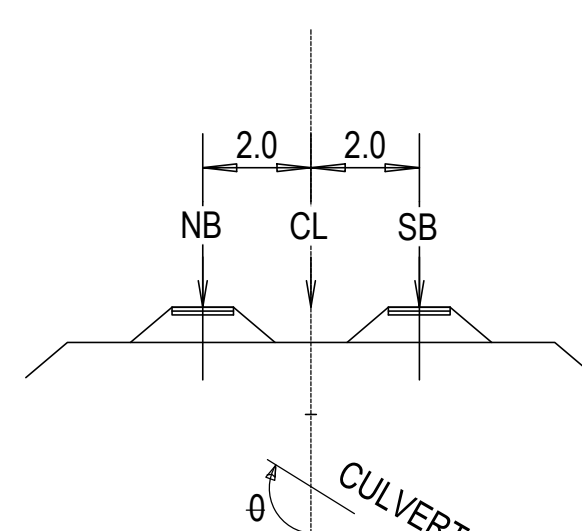

PROFILE OF GRADE LINE

HORIZONTAL SCALE 1 : 10000
VERTICAL SCALE 1 : 1000

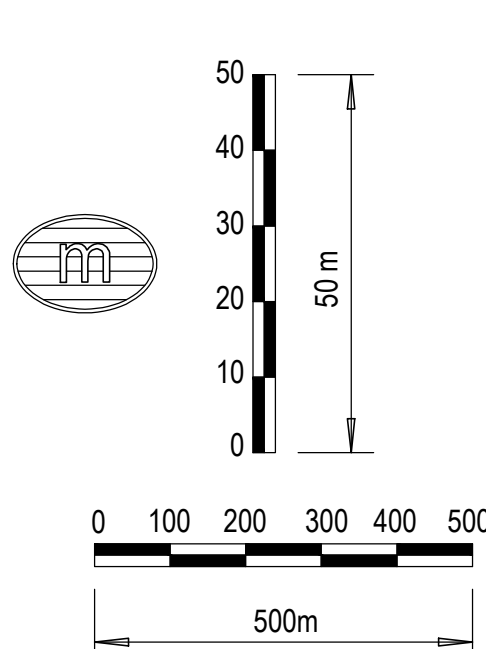

NGL ———
ROAD ———

SCALES:
Horizontal 1:10000
Vertical 1:1000
DATUM 1400.000

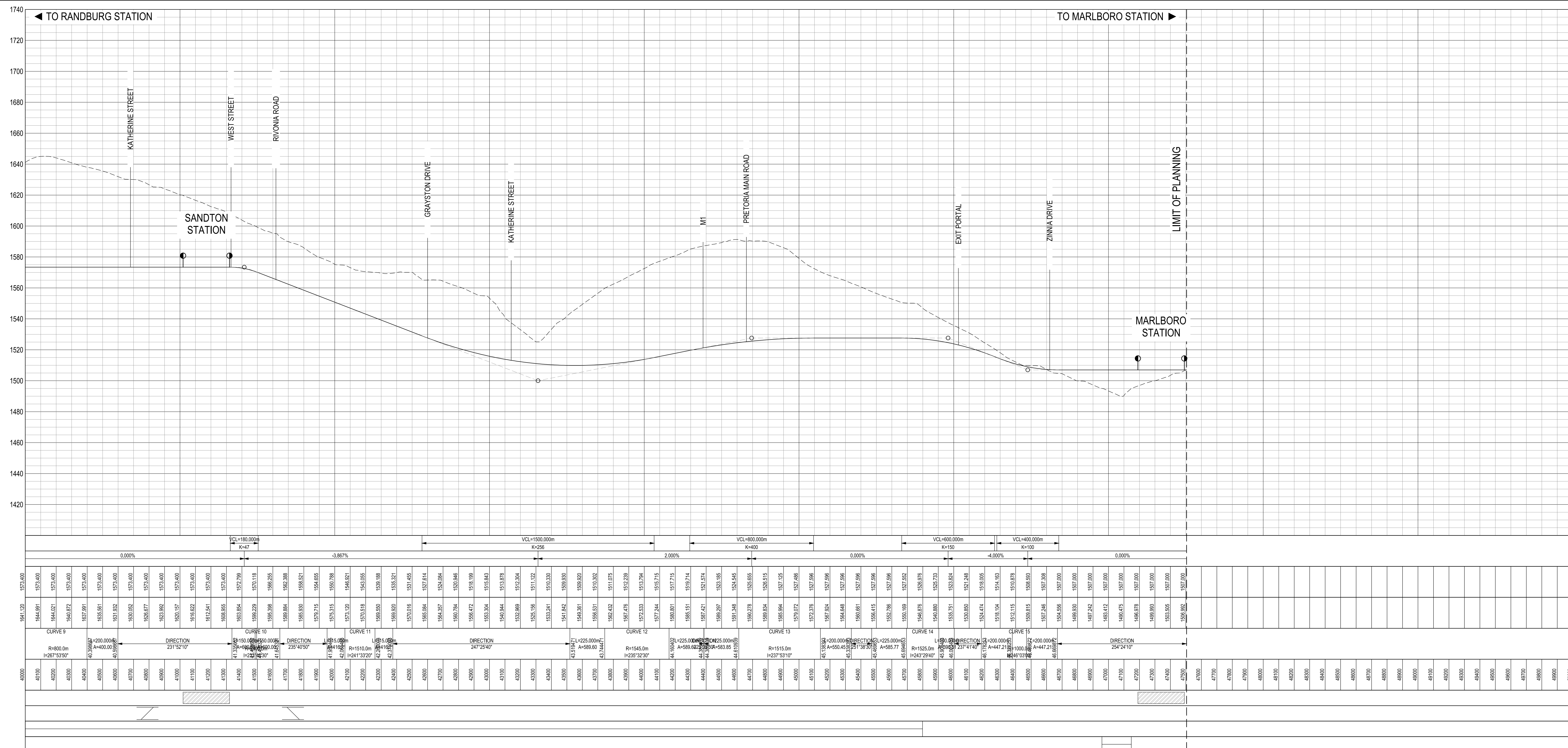

VERTICAL PROFILE GRADES
CENTRE LINE (CL)
GROUND LEVELS ON CL
HORIZONTAL ALIGNMENT
DISTANCE (m)
PLATFORMS
CROSS OVERS
TUNNELS
VIADUCTS

<p>CONSULTANTS:</p> <div style="display: flex; justify-content: space-around;"> </div> <div style="display: flex; justify-content: space-around; margin-top: 5px;"> </div>	<p>CLIENT:</p> <div style="display: flex; justify-content: space-around;"> </div>	<p>APPROVED</p> <div style="display: flex; justify-content: space-around;"> <div style="text-align: center;"> <p>for CONSULTING ENG.</p> <p>DATE: _____</p> </div> <div style="text-align: center;"> <p>for GAUTENG MANAGEMENT AGENCY</p> <p>DATE: _____</p> </div> </div>	<p>PROJECT:</p> <p style="text-align: center;">GAUTRAIN EXTENSION : PHASE 1</p>	<p>DRAWING DESCRIPTION:</p> <p style="text-align: center;">PROPOSED ROUTE ALIGNMENT 2</p> <p style="text-align: center;">(SHEET 4 OF 4)</p>	<p>SCALE</p> <p>AS SHOWN</p> <hr/> <p>PAPER SIZE</p> <p>A0</p>	<p>TYPE OF PLANNING</p> <p>ROUTE DETERMINATION</p> <hr/> <p>DRAWING NUMBER</p> <p>ALT ROUTE 02-04</p>									
<table border="1" style="width: 100%; border-collapse: collapse;"> <thead> <tr> <th>No.</th> <th>DATE</th> <th>AMENDMENTS</th> </tr> </thead> <tbody> <tr> <td> </td> <td> </td> <td> </td> </tr> <tr> <td> </td> <td> </td> <td> </td> </tr> </tbody> </table>							No.	DATE	AMENDMENTS						
No.	DATE	AMENDMENTS													

ROUTE ALIGNMENT OPTION 3 DRAWINGS



South Africa





LEGEND:

- PROPOSED ROUTE ALIGNMENT 3
- PLATFORM / STATION
- VIADUCT
- TUNNEL

LAYOUT PLAN
SCALE 1 : 10 000

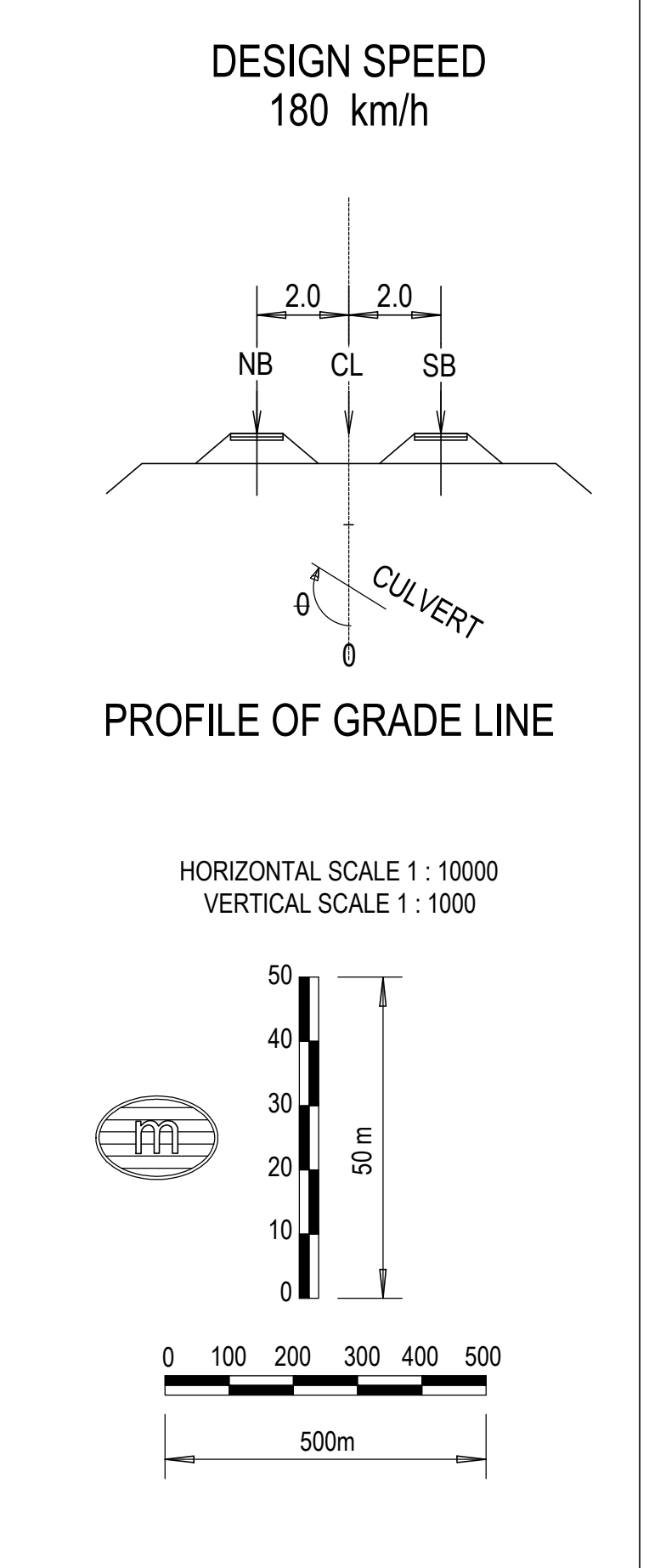

DESIGN SPEED
180 km/h

NGL ---
ROAD —

SCALES:
Horizontal 1:10000
Vertical 1:1000
DATUM 1400.000

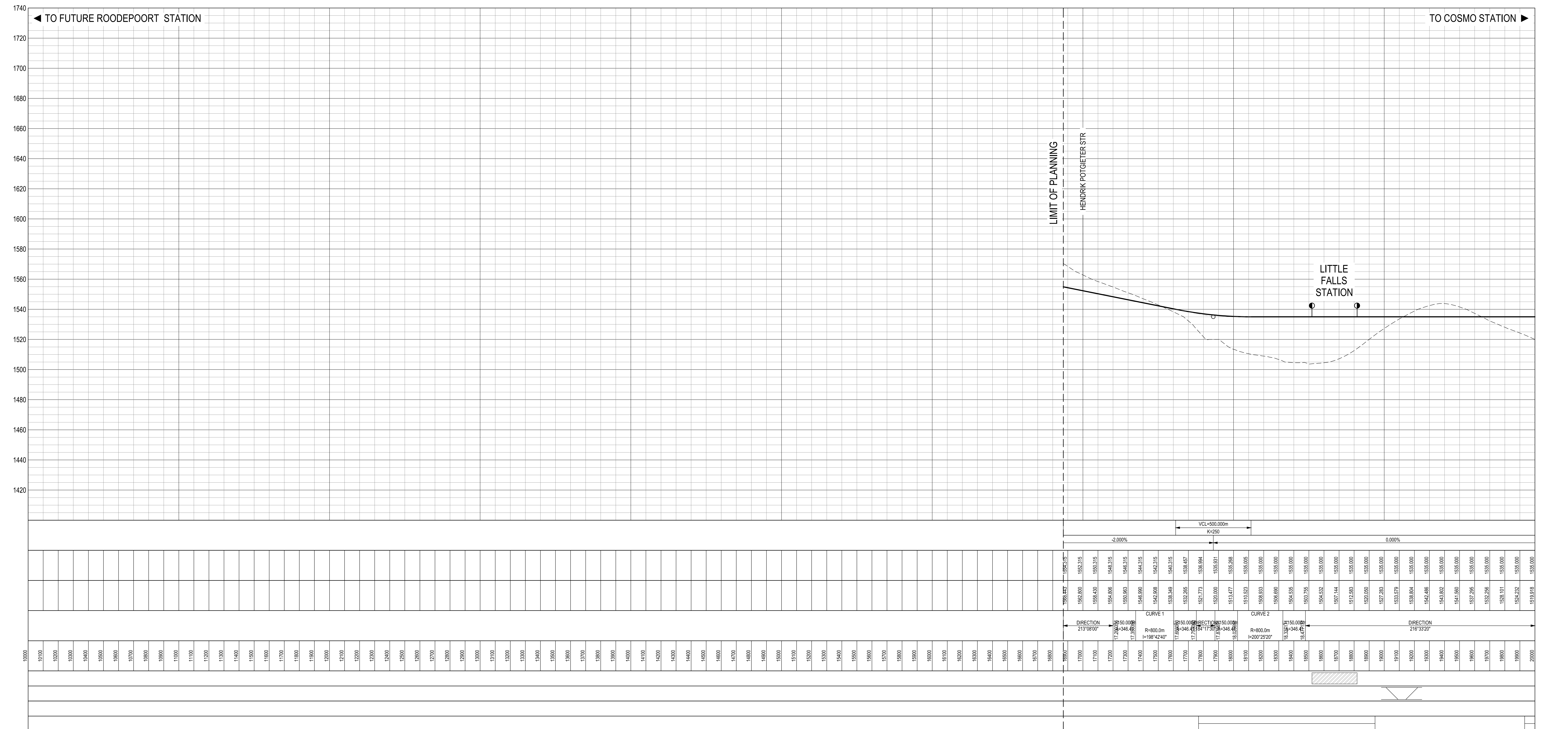

	<p>CONSULTANTS:</p>	<p>CLIENT:</p>	<p>APPROVED</p> <p>for CONSULTING ENG. _____</p> <p>for GAUTENG MANAGEMENT AGENCY _____</p>	<p>PROJECT:</p> <p>GAUTRAIN EXTENSION : PHASE 1</p>	<p>DRAWING DESCRIPTION:</p> <p>PROPOSED ROUTE ALIGNMENT 3 (SHEET 1 OF 4)</p>	<p>SCALE</p> <p>AS SHOWN</p> <p>PAPER SIZE A0</p>	<p>TYPE OF PLANNING</p> <p>ROUTE DETERMINATION</p> <p>DRAWING NUMBER PRO-ROUTE 03-01</p>
No.	DATE	AMENDMENTS					

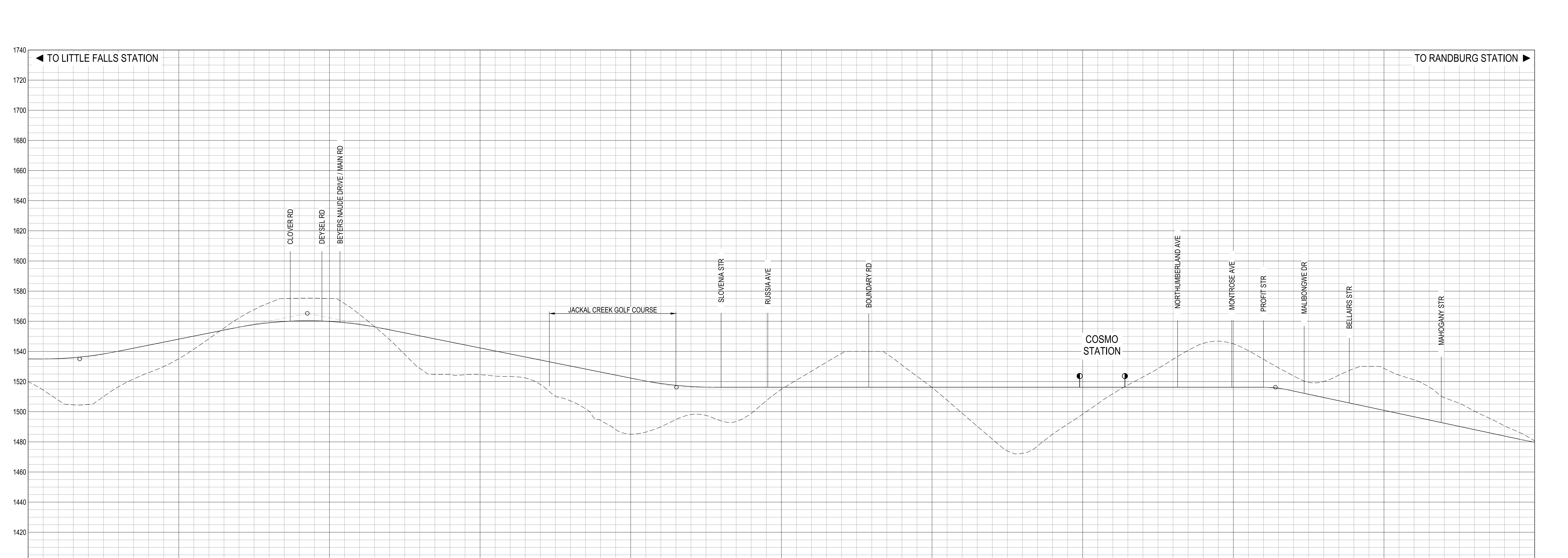
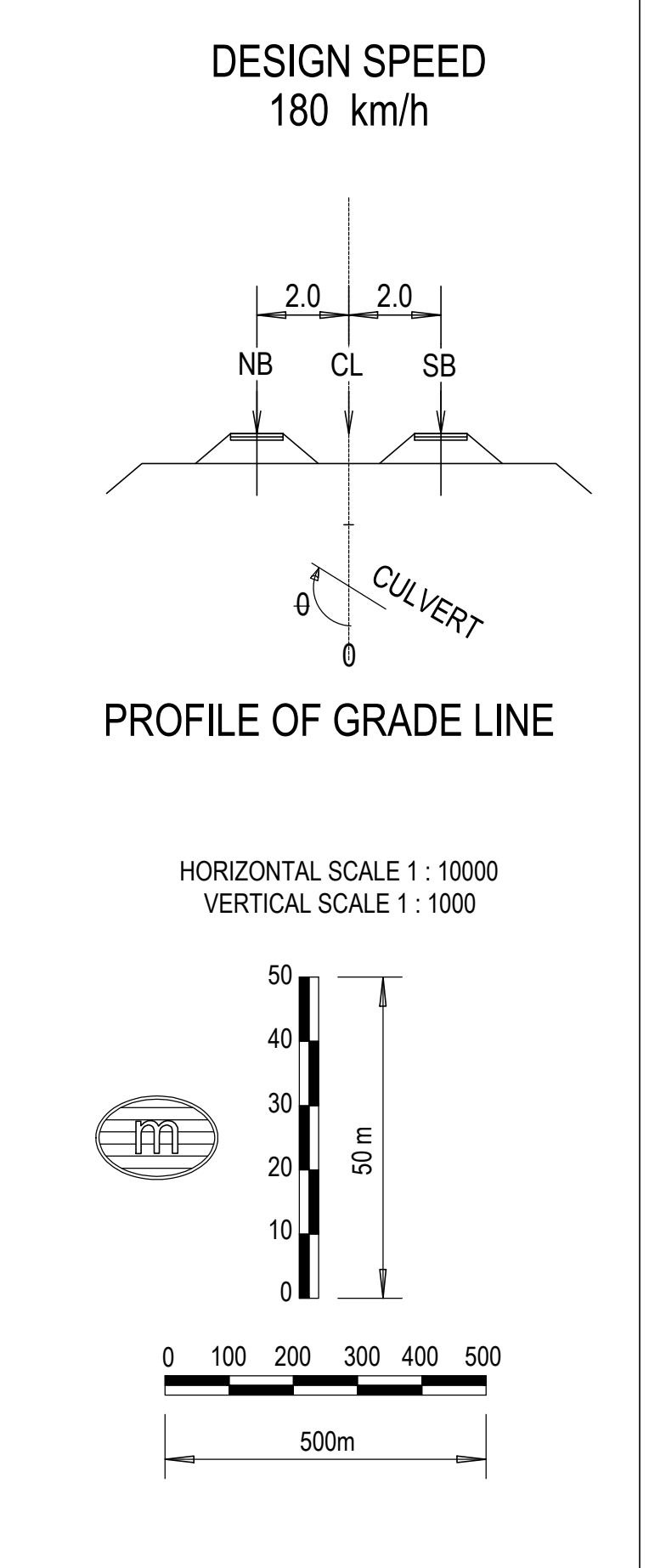

VERTICAL PROFILE GRADES
CENTRE LINE (CL)
GROUND LEVELS ON CL
HORIZONTAL ALIGNMENT
DISTANCE (m)
PLATFORMS

DIRECTION	VERTICAL CURVE DATA	GRADES (%)	STATIONING
DIRECTION 218°33'27"	VCL=500.00m K=200	0.00%	2000.000
DIRECTION 229°12'50"	VCL=980.00m K=245	2.00%	2100.000
DIRECTION 198°01'00"	VCL=500.00m K=200	-2.00%	2200.000
DIRECTION 303°55'57"	VCL=180.00m K=75	0.00%	2300.000
DIRECTION 303°55'57"	VCL=420.00m K=175	-2.12%	2400.000

No.	DATE	AMENDMENTS

CONSULTANTS: AECOM, GIBB, pwc, ZANECEO, LETSEMA, Alcost

CLIENT: GAUTRAIN, GAUTENG REPUBLIC OF SOUTH AFRICA

APPROVED: [Signature] for CONSULTING ENG. DATE: []

PROJECT: GAUTRAIN EXTENSION : PHASE 1

DRAWING DESCRIPTION: PROPOSED ROUTE ALIGNMENT 3 (SHEET 2 OF 4)

SCALE: AS SHOWN

TYPE OF PLANNING: ROUTE DETERMINATION

PAPER SIZE: A0

DRAWING NUMBER: PRO-ROUTE 03-02

LEGEND:

- PROPOSED ROUTE ALIGNMENT 3
- PLATFORM / STATION
- VIADUCT
- TUNNEL

LAYOUT PLAN
SCALE 1 : 10 000

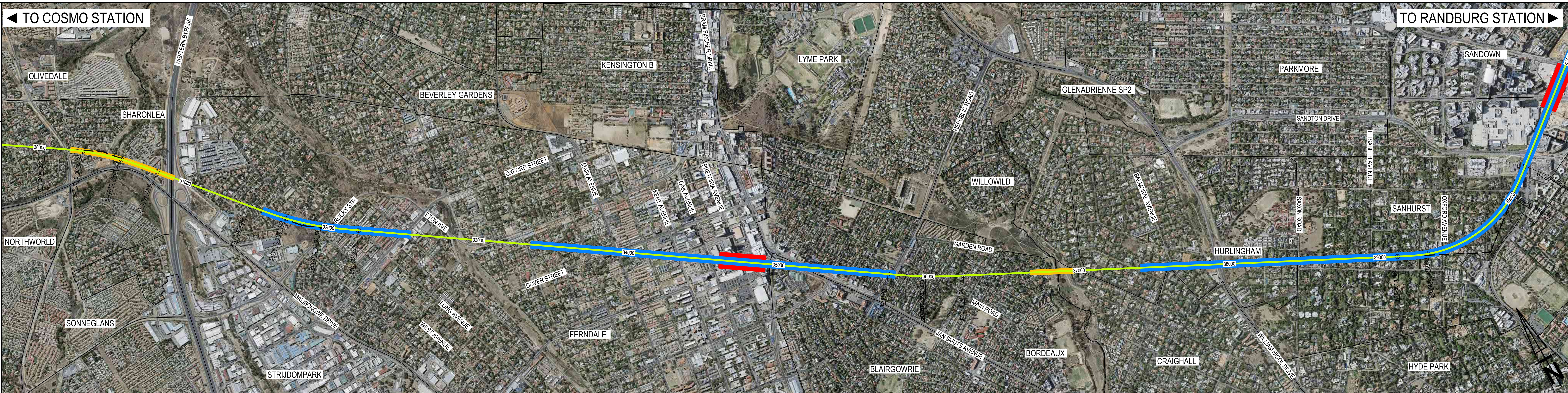

DESIGN SPEED
180 km/h

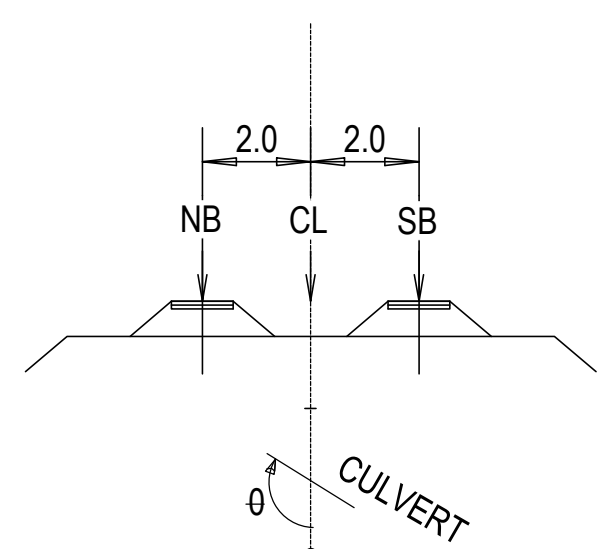

PROFILE OF GRADE LINE

HORIZONTAL SCALE 1 : 10000
VERTICAL SCALE 1 : 1000

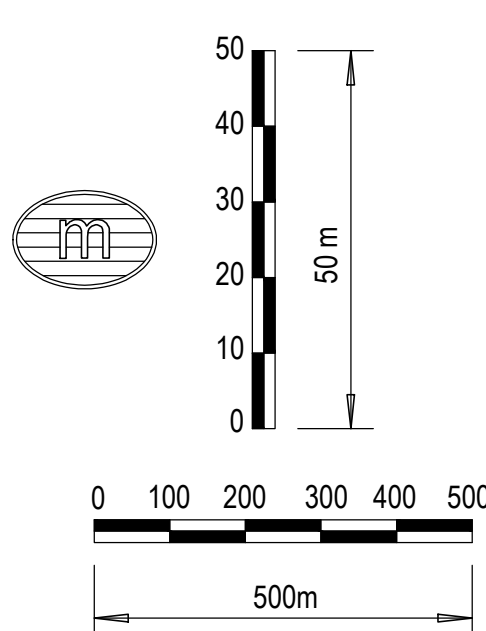

NGL ---
ROAD —

SCALES:
Horizontal 1:10000
Vertical 1:1000
DATUM 1400.000

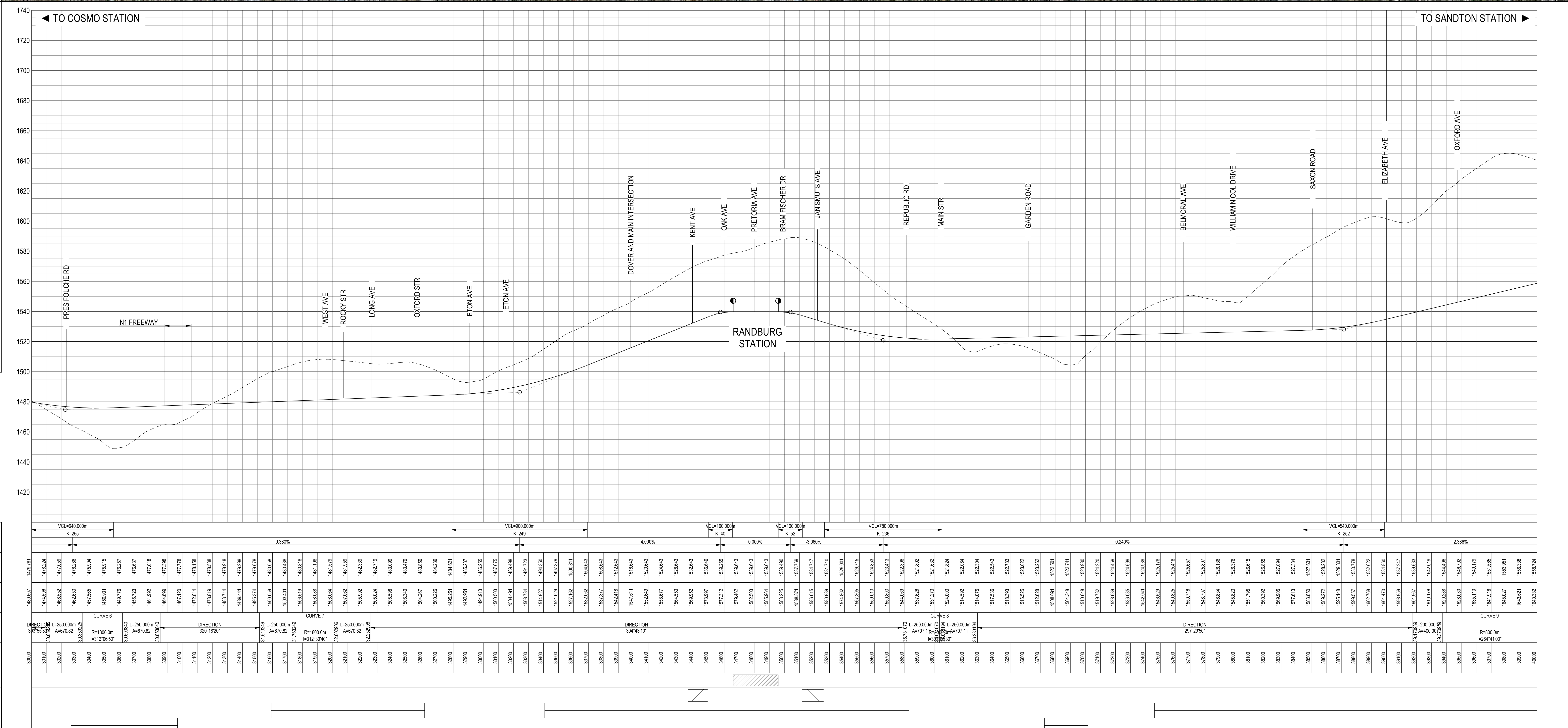

CONSULTANTS:



A BARNARD
DESIGN

R VAN NEKERK
DRAWN

F MARUTLA
CHECKED

CLIENT:



APPROVED

for CONSULTING ENG.
DATE: _____

for GAUTENG MANAGEMENT AGENCY
DATE: _____

PROJECT:

GAUTRAIN EXTENSION : PHASE 1

DRAWING DESCRIPTION:

PROPOSED
ROUTE ALIGNMENT 3
(SHEET 3 OF 4)

SCALE

AS SHOWN

PAPER SIZE
A0

TYPE OF PLANNING

ROUTE DETERMINATION

DRAWING NUMBER

PRO-ROUTE 03-03

No.	DATE	AMENDMENTS

- LEGEND:**
- PROPOSED ROUTE ALIGNMENT 3
 - PLATFORM / STATION
 - VIADUCT
 - TUNNEL

LAYOUT PLAN
SCALE 1 : 10 000

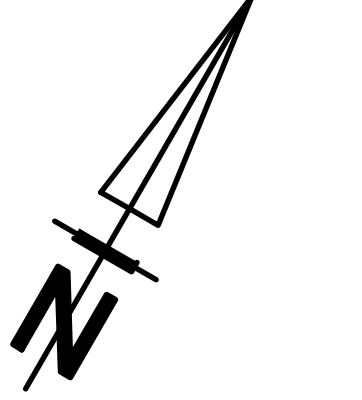
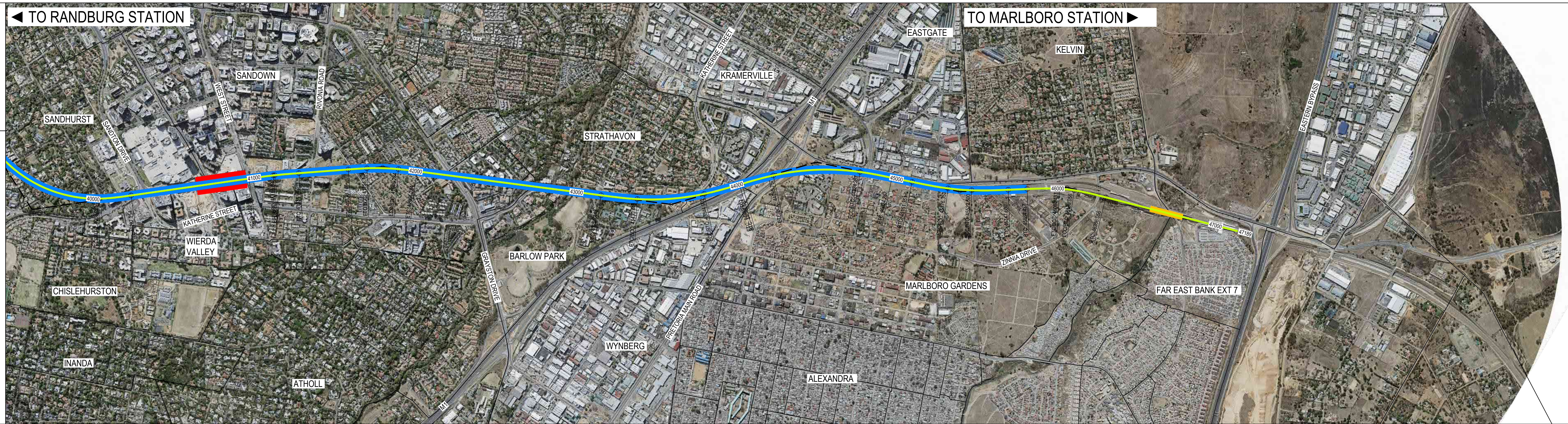

DESIGN SPEED
180 km/h

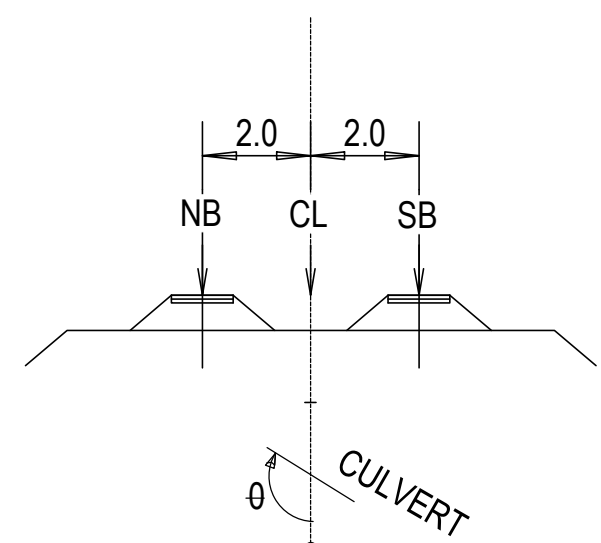

PROFILE OF GRADE LINE

HORIZONTAL SCALE 1 : 10000
VERTICAL SCALE 1 : 1000

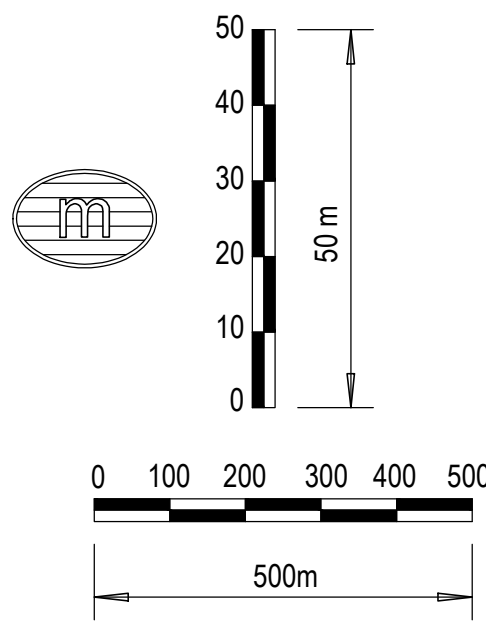

NGL ---
ROAD ——

SCALES:
Horizontal 1:10000
Vertical 1:1000
DATUM 1400.000

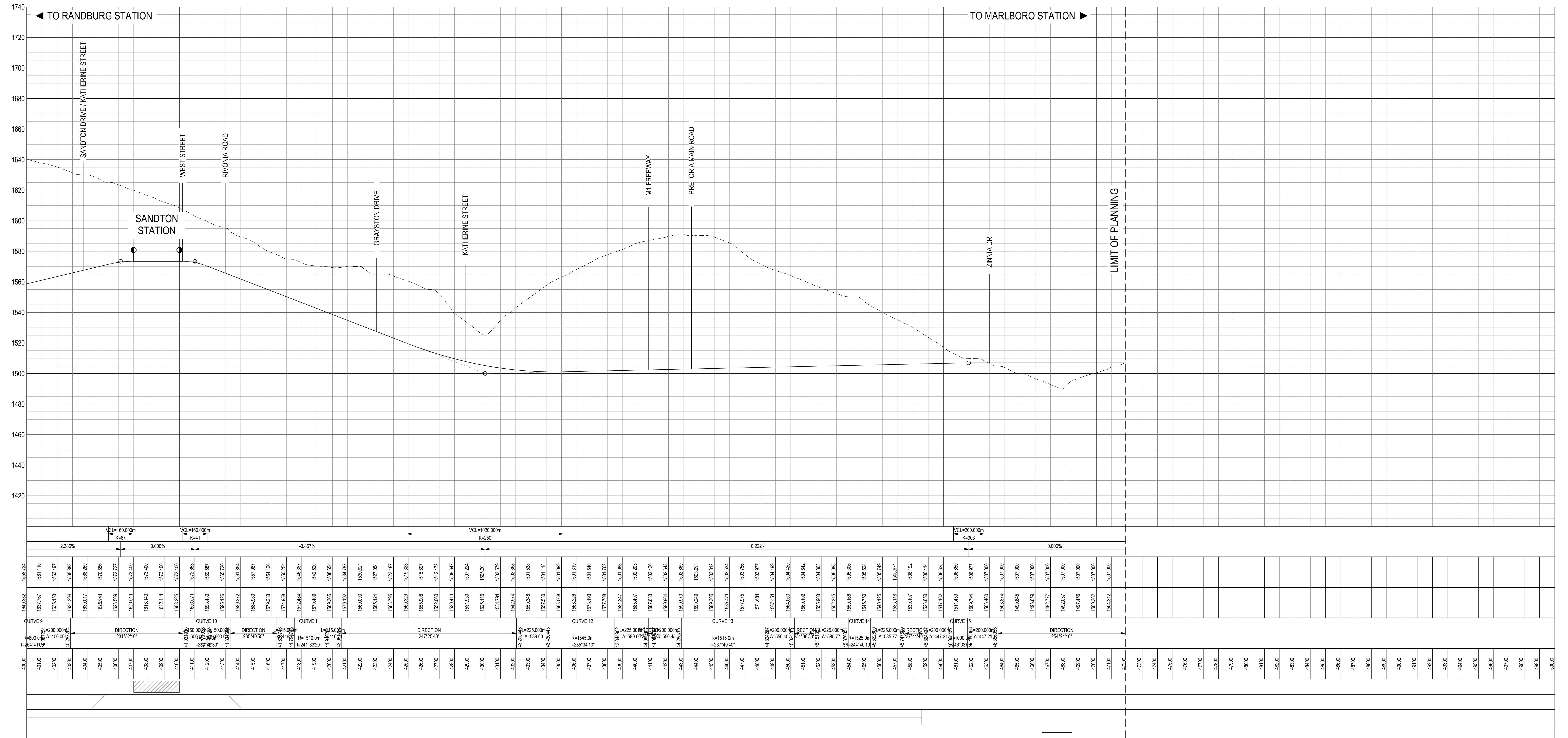

<table border="1" style="width: 100%; border-collapse: collapse;"> <tr><td>VERTICAL PROFILE GRADES</td></tr> <tr><td>CENTRE LINE (CL)</td></tr> <tr><td>GROUND LEVELS ON CL</td></tr> <tr><td>HORIZONTAL ALIGNMENT</td></tr> <tr><td>DISTANCE (m)</td></tr> <tr><td>PLATFORMS</td></tr> <tr><td>CROSS OVERS</td></tr> <tr><td>TUNNELS</td></tr> <tr><td>VIADUCTS</td></tr> </table>	VERTICAL PROFILE GRADES	CENTRE LINE (CL)	GROUND LEVELS ON CL	HORIZONTAL ALIGNMENT	DISTANCE (m)	PLATFORMS	CROSS OVERS	TUNNELS	VIADUCTS	<p>CONSULTANTS:</p>	<p>CLIENT:</p>	<p>APPROVED</p> <p>for CONSULTING ENG. _____</p> <p>for GAUTENG MANAGEMENT AGENCY _____</p> <p>DATE: _____</p>	<p>PROJECT:</p> <p>GAUTRAIN EXTENSION : PHASE 1</p>	<p>DRAWING DESCRIPTION:</p> <p>PROPOSED ROUTE ALIGNMENT 3 (SHEET 4 OF 4)</p>	<p>SCALE</p> <p>AS SHOWN</p>	<p>TYPE OF PLANNING</p> <p>ROUTE DETERMINATION</p>
	VERTICAL PROFILE GRADES															
CENTRE LINE (CL)																
GROUND LEVELS ON CL																
HORIZONTAL ALIGNMENT																
DISTANCE (m)																
PLATFORMS																
CROSS OVERS																
TUNNELS																
VIADUCTS																
<table border="1" style="width: 100%; border-collapse: collapse;"> <tr> <th>No.</th> <th>DATE</th> <th>AMENDMENTS</th> </tr> <tr> <td> </td> <td> </td> <td> </td> </tr> <tr> <td> </td> <td> </td> <td> </td> </tr> <tr> <td> </td> <td> </td> <td> </td> </tr> </table>	No.	DATE	AMENDMENTS										<p>PAPER SIZE</p> <p>A0</p>	<p>DRAWING NUMBER</p> <p>PRO-ROUTE 03-04</p>		
No.	DATE	AMENDMENTS														